

Researching the Energy Technology of UFOs

Thomas Valone, PhD, PE

IntegrityResearchInstitute.org

Washington DC

We Are Here

Younger stars are in the spiral arms of the galaxy

Milky Way Galaxy
•
Black Hole Center

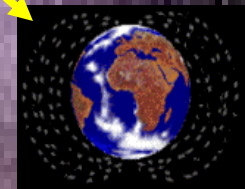

Earth is in the Outer Limits of Suburbia -- the Spiral Arms at 50,000 Light Years from the Center

www.NASA.gov

A satellite image of Earth at night, showing the continents of North America, South America, and Europe. The landmasses are illuminated by a dense network of yellow and white lights, representing artificial activity. The oceans are dark, with some faint lights visible along the coastlines. The text is overlaid on the bottom half of the image.

Night Lights Visible from
Space Advertise Lots of
Artificial Activity on Earth

Such as the
Unidentified
Frivolous
Objects
found in
Las Vegas



The Washington Post

MONDAY, JUNE 29, 1998

June 29, 1998, p.A1



Near Roswell, N.M., where a 1947 incident led to much speculation about flying saucers, a sign guides visitors.

Panel Urges Study Of UFO Reports

Unexplained Phenomena Need Scrutiny, Science Group Says

By KATHY SAWYER
Washington Post Staff Writer

Some supposed UFO sightings have been accompanied by unexplained physical evidence that deserves serious scientific study, an international panel of scientists has concluded.

In the first independent scientific review of the controversial topic in almost 30 years, directed by physicist Peter Sturrock of Stanford University, the panel emphasized that it had found no convincing evidence of extraterrestrial intelligence or any violation of natural laws.

But the panel cited cases that included intriguing and inexplicable details, such as burns to witnesses, radar detections of mysterious objects, strange lights appearing repeatedly in the skies over certain locales, aberrations in the workings of automobiles, and radiation and other damage found in vegetation.

The 50-page review, being released today, asserts that the scientific community might learn something worthwhile if it can overcome the fear of ridicule associated with the topic and get some funding for

See UFO, A7, Col. 1

Study of UFO-Related Phenomena Urged

UFO, From A1

targeted research to try to explain these occurrences.

"It may be valuable to carefully evaluate UFO reports to extract information about unusual phenomena currently unknown to science," the report stated, adding that such research could also improve understanding of, and in some cases debunk, supposed UFO events.

For example, Earth science researchers have eventually accepted several phenomena "originally dismissed as folk tales," including meteorites and certain types of lightning, the panel noted.

The findings are from a four-day workshop held in Tarrytown, N.Y., followed by a second three-day meeting in San Francisco, both last fall. The results are published in the current issue of the *Society for Scientific Exploration*, which was established by Sturrock.

The inquiry involved scientists from the Massachusetts Institute of Technology, Cornell and Princeton universities, the universities of Arizona and Virginia, and institutions in France and Germany, among others. A panel of nine physical scientists analyzed presentations by eight UFO investigators, who were encouraged to present their strongest evidence. The project was funded by Laurance S. Rockefeller through his LSR Fund because of a belief, the report said, that "the problem is in a very unsatisfactory state of ignorance and confusion."

The panel suggests the scientific community has suffered a failure of curiosity regarding UFOs. Despite an abundance of reports over the last 50 years, "and despite great public interest, the scientific community has shown remarkably little interest in this topic."

Asked about the conclusions, a sampling of scientists and officials outside the panel expressed surprise that a topic with such a high "giggle factor" might be reincarnated for serious study, possibly further blurring the lines between legitimate research and the "lunatic fringe." Some said they would never comment on the touchy topic, and some said they would reserve judgment until they had read the report.

In a telephone interview, Sturrock said that he hopes at least some scientists "will read the report and become curious. . . . The challenge is to do good science on this issue. It's difficult."

Some reported UFO incidents could have been caused by rare natural phenomena, such as electrical activity high above thunderstorms, or other known physical effects, the panel found. But there were some phenomena they could not easily explain.

The existing evidence from past cases is unlikely to produce either a solid debunking or other satisfactory explanation of the reports, the panel found. But "new data, scientifically acquired and analyzed (especially of well-documented, recurrent events) could yield useful information." The panel urged the scientific community to take UFO "evaluations must take place with a spirit of objectivity and a willingness to evaluate rival hypothe-

ses" that so far has been lacking, the report said.

Among the potentially fruitful areas of investigation the panel cites are:

- Physical effects on witnesses. Burns, or sensations of heat, and eye problems are the most frequently reported forms. The available evidence, though sparse, suggests microwave, infrared, visible and ultraviolet radiation, although "a few cases seem to point toward high doses of ionizing radiation, such as X-rays or gamma rays."
- Radar detections of UFOs. Scientific study would require the cooperation of military authorities. An example occurred in January 1994, in the skies above Paris, when an airborne crew saw "a gigantic disk" more than 3,000 feet in diameter. The disk was detected on military radar for 50 seconds, slowed abruptly from 110 knots to zero, then disappeared.

■ Semi-regular sightings of strange lights (such as those in Hessdalen, Norway, and Marfa, Tex.), in some cases accompanied by reports of disembarking objects. A possible example occurred in Ohio in 1973. A number of witnesses, both on the ground and in an Army Reserve helicopter, saw lights, including a powerful green light, and a bright white starburst. On one occasion, the starburst reappeared and again illuminated the set for descent. Scientists apparently failed to investigate the one item of physical evidence—a magnetic compass that had begun to spin during the event and was subsequently removed because it was unserviceable.

■ Injuries to vegetation and other ground traces. In a 1981 case in Trans-en-Provence, France, a witness reported an ovoid object emitting a low whistle as it flew in for a landing. Police and special UFO researchers found two concentric circles and other traces that, when subjected to laboratory analysis, showed the soil had been heavily compacted, though without major heating, and there were symptoms of aging in the plants there. A toxicologist concluded that some, though not all, of the effects could have been caused by powerful microwave radiation.

The Sturrock group said that because of advances in knowledge and technical capability, chances of significant learning are greater now than 30 years ago when the Air Force and the CIA supported a two-year investigation by the Colorado Project, directed by Edward U. Condon. That 1968 report concluded that "further extensive study of UFOs probably cannot be justified in the expectation that science will be advanced."

The Air Force last year made public its latest report on the infamous 1947 incident near the town of Roswell, N.M., which gave rise to a whole flying-saucer culture of paranoia, up to and including the fictional television program "The X-Files." Titled "The Roswell Report: Case Closed," that report, like the Sturrock panel, reiterated earlier conclusions that there is no evidence of aliens or their spaceships.

"gravitational and inertial effects"

J. of Sci. Explor., V. 12, No 3, 1998

New Book Reveals Black Project Power & Domination Themes

Small Map on
Patch Shows
Location of
Area 51
Groom Lake

**Authentic
Black Project
patch**





I COULD TELL YOU
BUT THEN YOU WOULD HAVE TO
BE DESTROYED BY ME

EMBLEMS FROM THE PENTAGON'S BLACK WORLD

TREVOR PAGLEN



MELVILLE HOUSE PUBLISHING
BROOKLYN, NEW YORK WWW.MHPBOOKS.COM

New 2008 book published about Pentagon's Black World

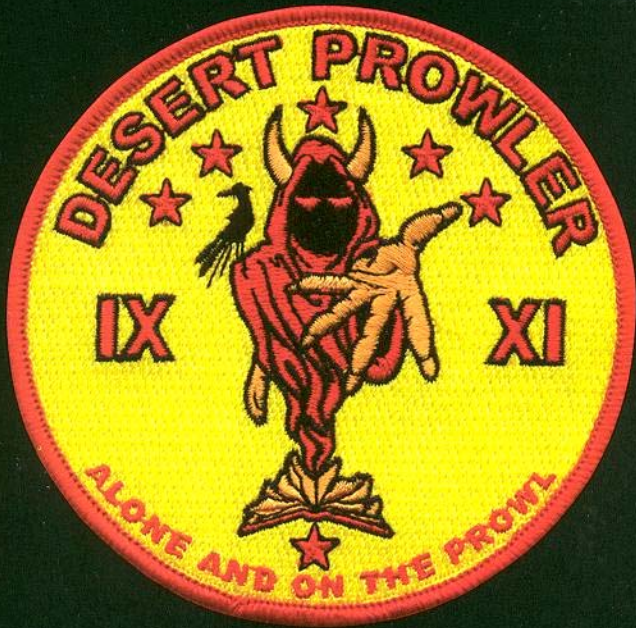

“Freedom in the Cosmos”



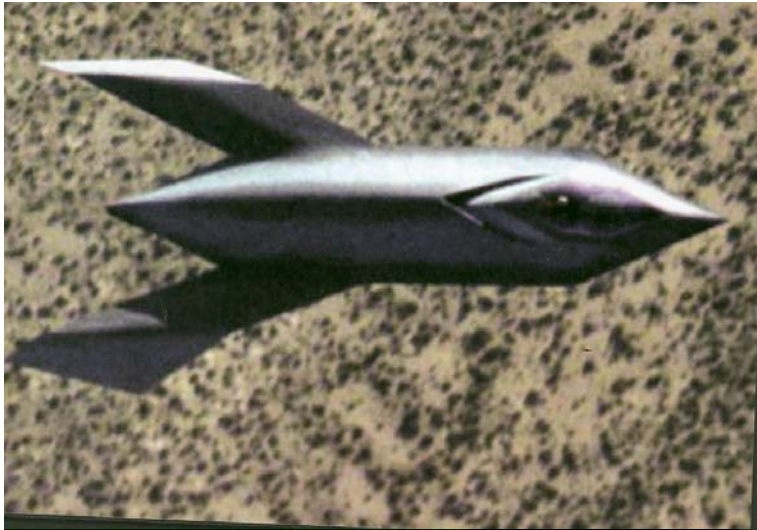

**Recently declassified
Black Project plane**

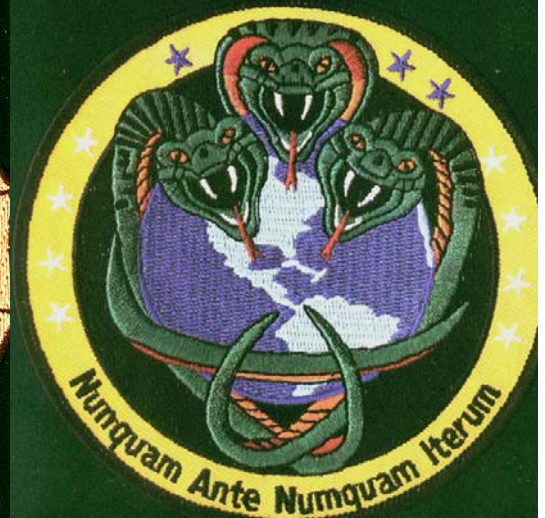

**NRO Black
Projects**



**Still
classified
Minotaur
Black
Project**



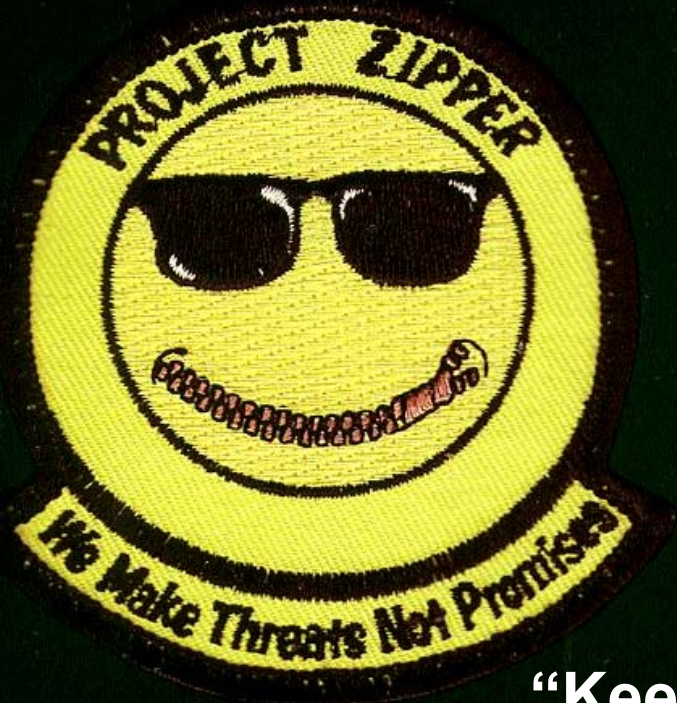

“Let them hate so long as they fear”



“Keep your distance you ... uninitiated”



“tastes like chicken”

How Can Civilians Visit Mars?

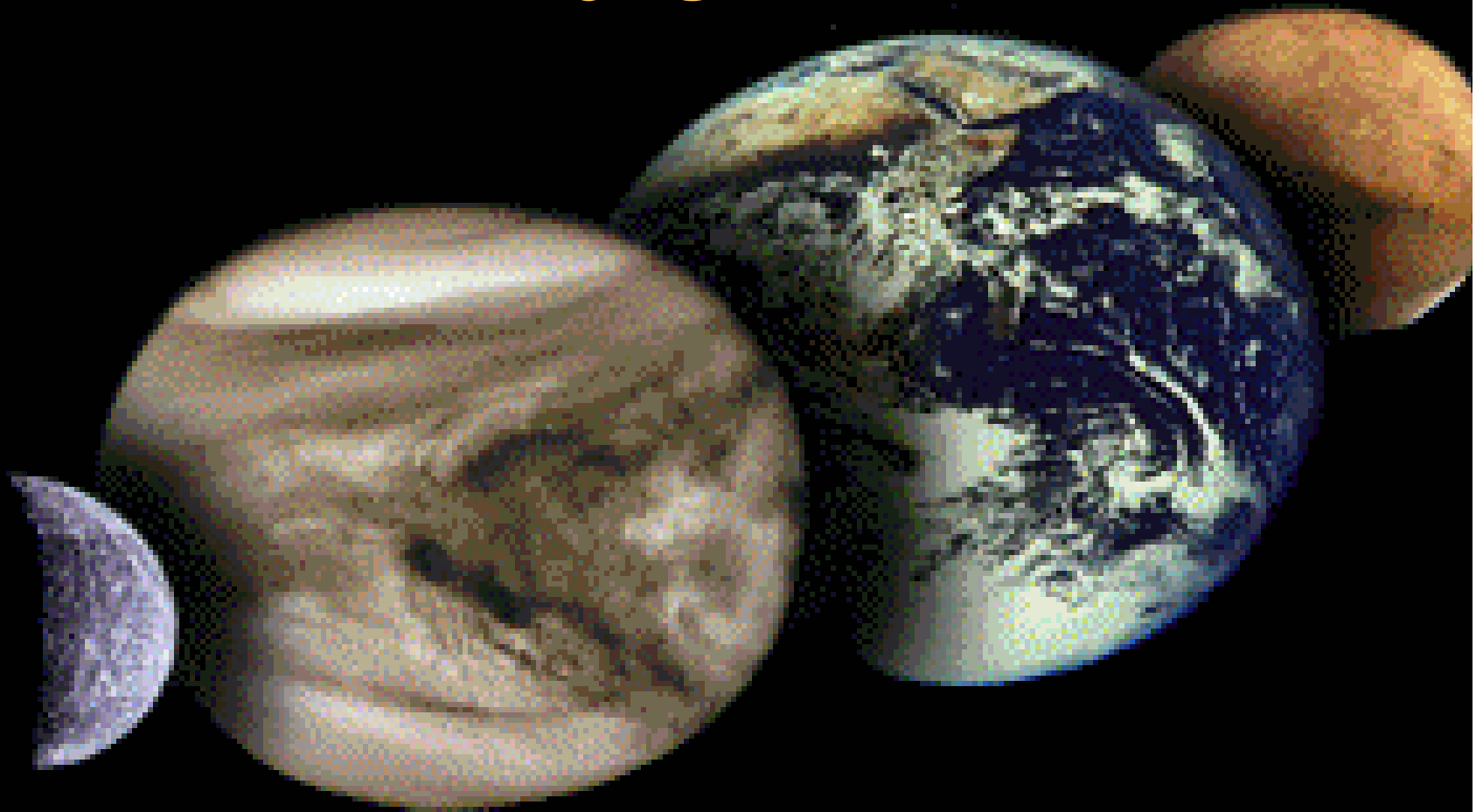

CERTAINLY NOT BY CARRYING FUEL



TRIAL & ERROR

NASP, 1986

Shortly after the Challenger disaster in 1986, President Ronald Reagan launched the National Aerospace Plane (NASP) project. It was to take off like an airplane from a conventional runway and fly straight into orbit, burning semi-frozen "slush" hydrogen in a revolutionary new supersonic combustion ramjet (scramjet) engine. By 1992 it was clear that the scramjet idea was ahead of its time—nobody knew whether the engine could operate at the hypersonic speeds that it had to in order for NASP to work. The project was scaled back, then canceled in 1993.



Delta Clipper, 1991

McDonnell Douglas began this effort in the late 1980s. In addition to being a reusable space vehicle, the Delta Clipper would have been a key component of the Star Wars missile-defense program. The reusable rocket, shaped like an inverted ice-cream cone, took off and landed vertically. A low-speed test vehicle was built for some experimental hops, but when Star Wars was scaled back, Delta Clipper lost most of its funding. The test vehicle was destroyed in an accident in 1996.



X-33, 1996

Lockheed Martin won the right to build the prototype X-33 in 1996. It was a wedge-shaped "lifting-body" vehicle that took off vertically like a rocket and landed like an airplane, and it had a unique "linear aerospike" rocket engine arrayed across its tail. The challenge was making the vehicle light enough to carry a payload in addition to the fuel needed to reach orbit. To do this, Lockheed Martin counted on carbon-fiber-composite tanks of liquid hydrogen. These proved too hard to build with current technology, and after a series of problems the X-33 was canceled in early 2001.

World Oil Production

Peak expected on or before 2010, like US 1970 peak, to which it never returns

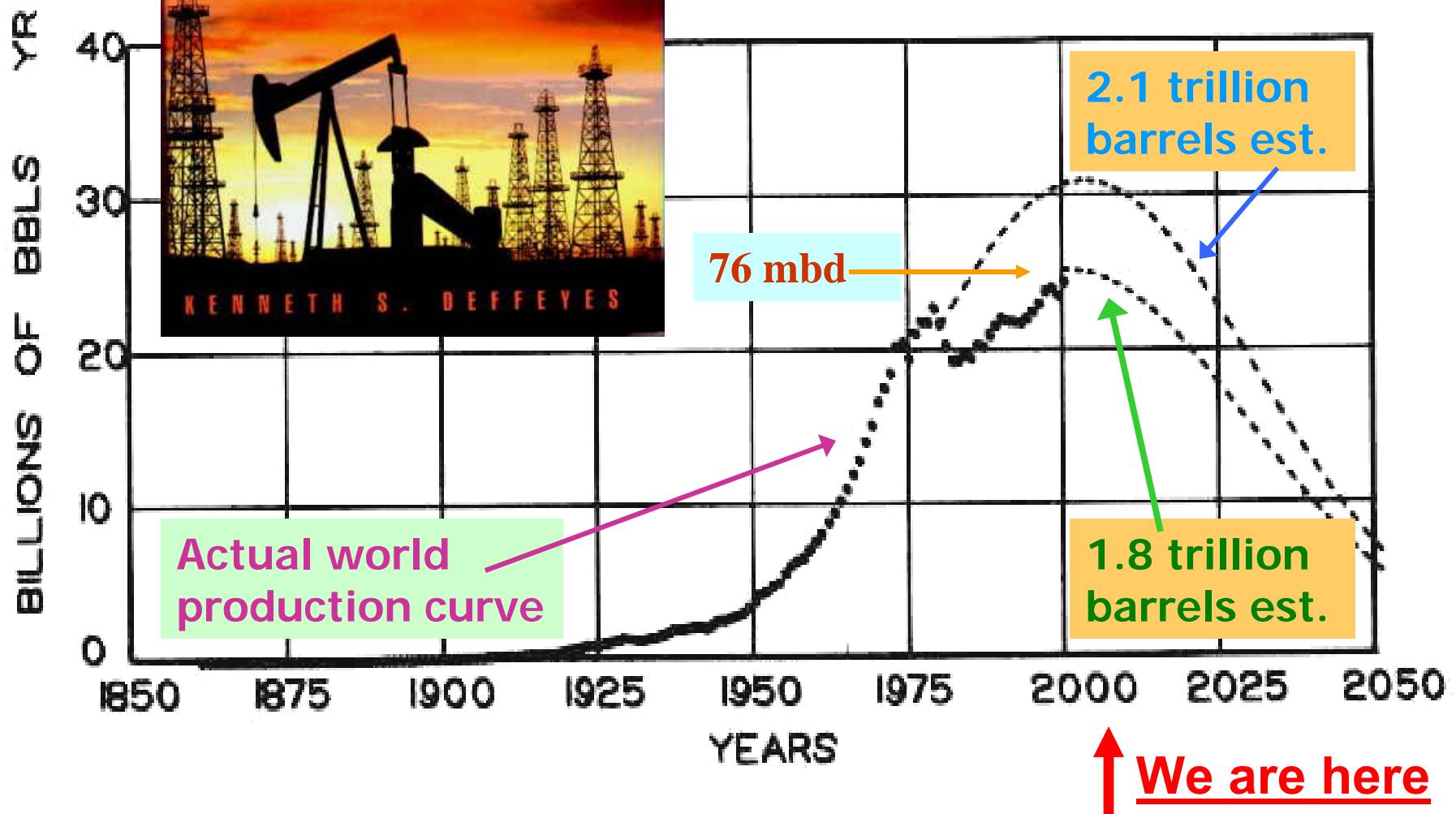

“We’re pretending that business as usual will supply all our needs. But there’s an impending oil crisis we’re basically seeing, that will actually bite us sooner than we’re expecting it and it’s better to prepare for it now.”

Tom Valone, June 25, 2002 - CNN Moneyline



Integrity Research Institute

- **ENERGY RESEARCH AND EDUCATION WITH SCIENTIFIC INTEGRITY**
- **Conferences, Books, Reports & free Future Energy eNews**

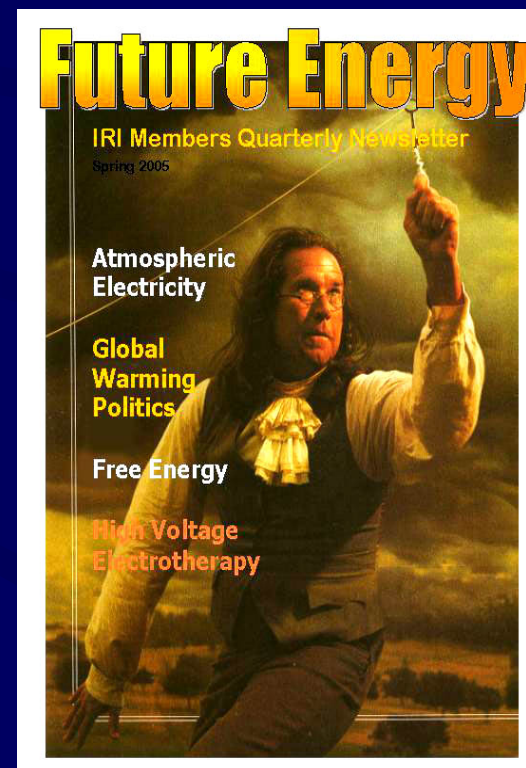
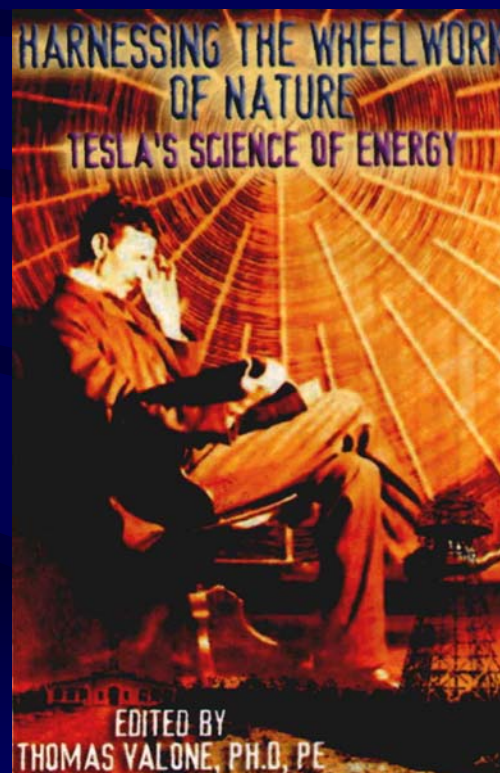
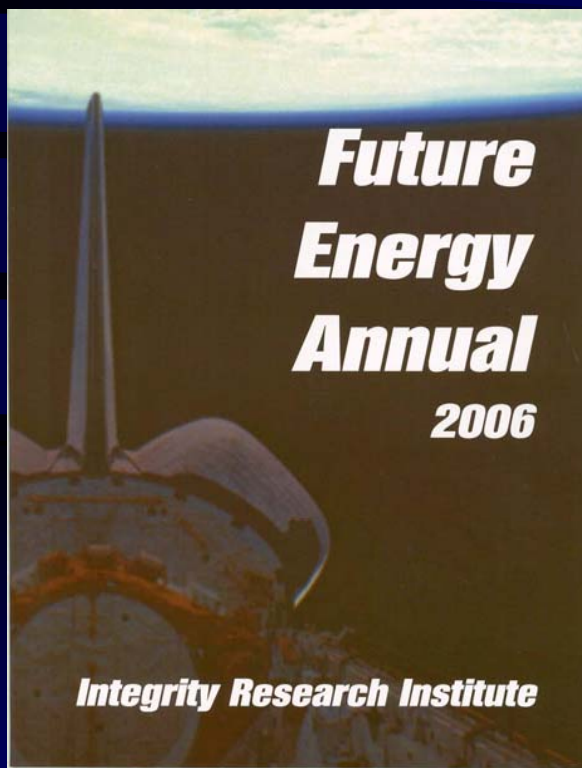

- ***ADVOCACY FOR THE COMMON GOOD without favoritism***
nonprofit 501(c)3 organization that accepts tax-deductible donations

IRI Future Energy Projects Related to UFOs

- 1) Electromagnetic Healing Devices**
- 2) Permanent Magnetic Motors**
- 3) Quantum Vacuum Zero Point
Energy**
- 4) Space Propulsion Technology**

George Van Tassel & the Integratron

First IRI
Project:
EM Therapy

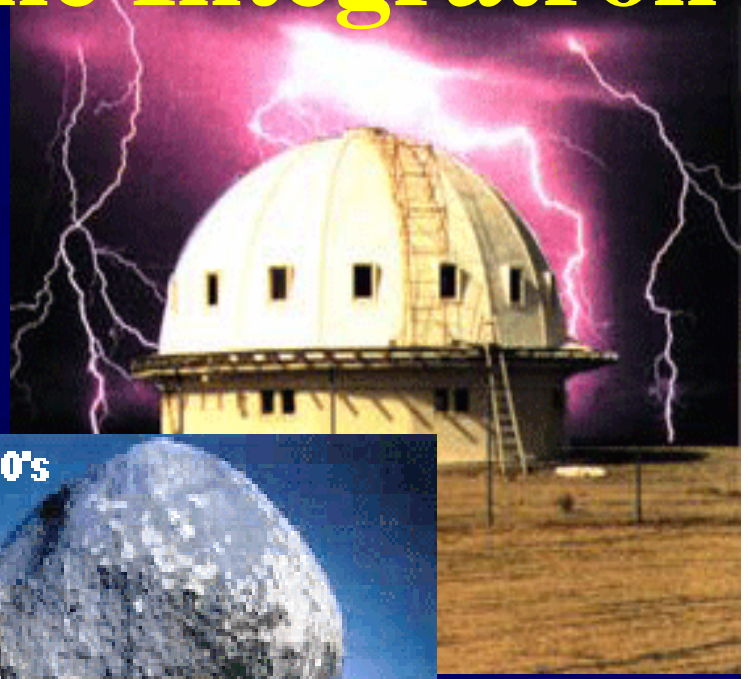

Giant Rock 1950's

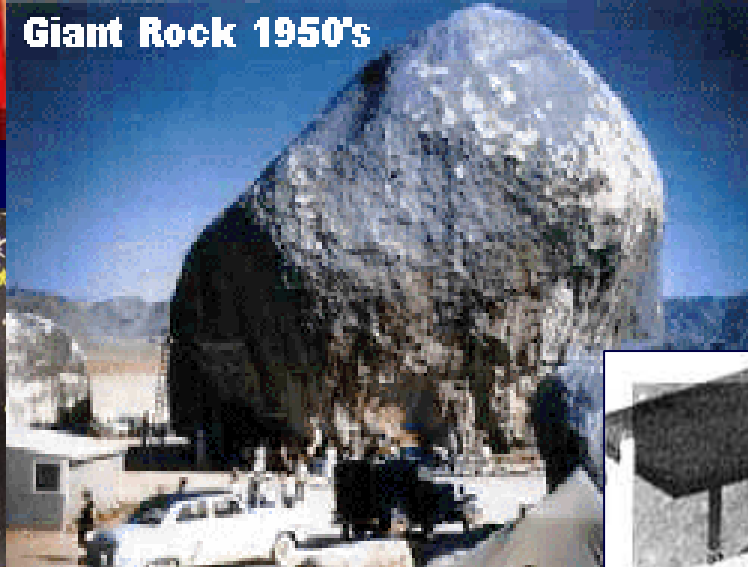

George and Eva Van Tassel
at their restaurant at Giant Rock

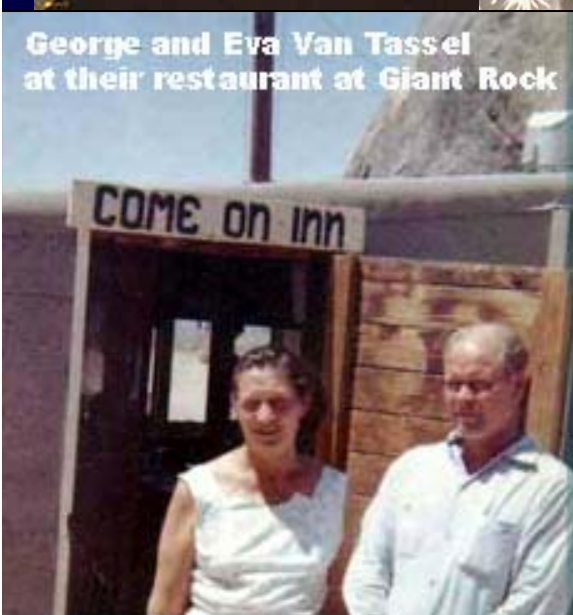

Repeated UFO
appearances



The Integratron Today

Flanders, CA

2477 Belfield Blvd.,

Flanders CA 92285

www.Integratron.com

Sound Healing Event – June 20-21, 2009

Upper Resonant Acoustic Chamber of Integratron

No nails were used in its construction



Primary and secondary Tesla coils



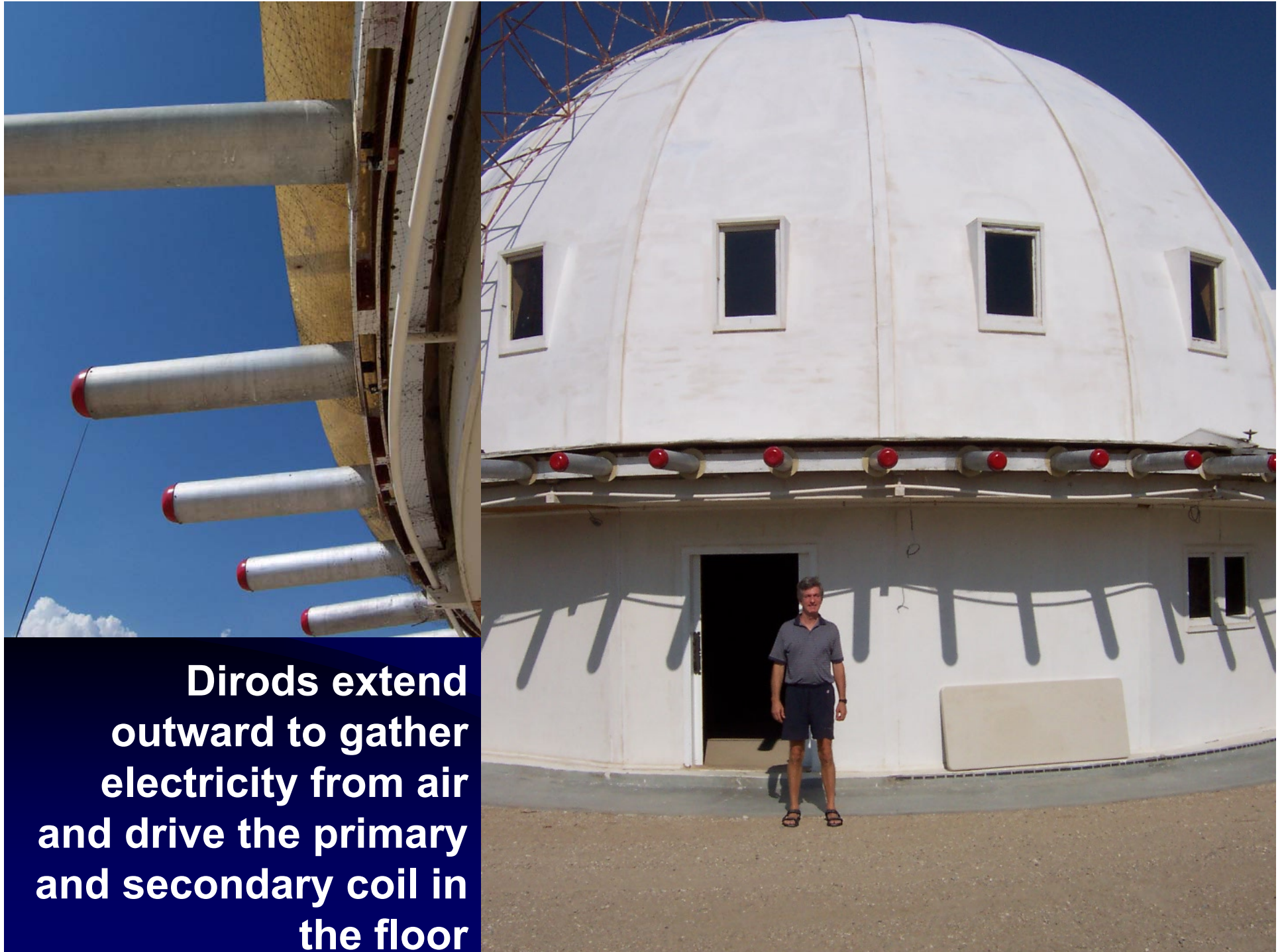

Dirods extend outward to gather electricity from air and drive the primary and secondary coil in the floor

The Integratron is a “Rejuvenation” Chamber

According to George Van Tassel who says he relied upon Georges Lakhovsky T. Townsend Brown Nikola Tesla and ET's for the Integratron design that has an atmospheric energy input **Tesla coil**

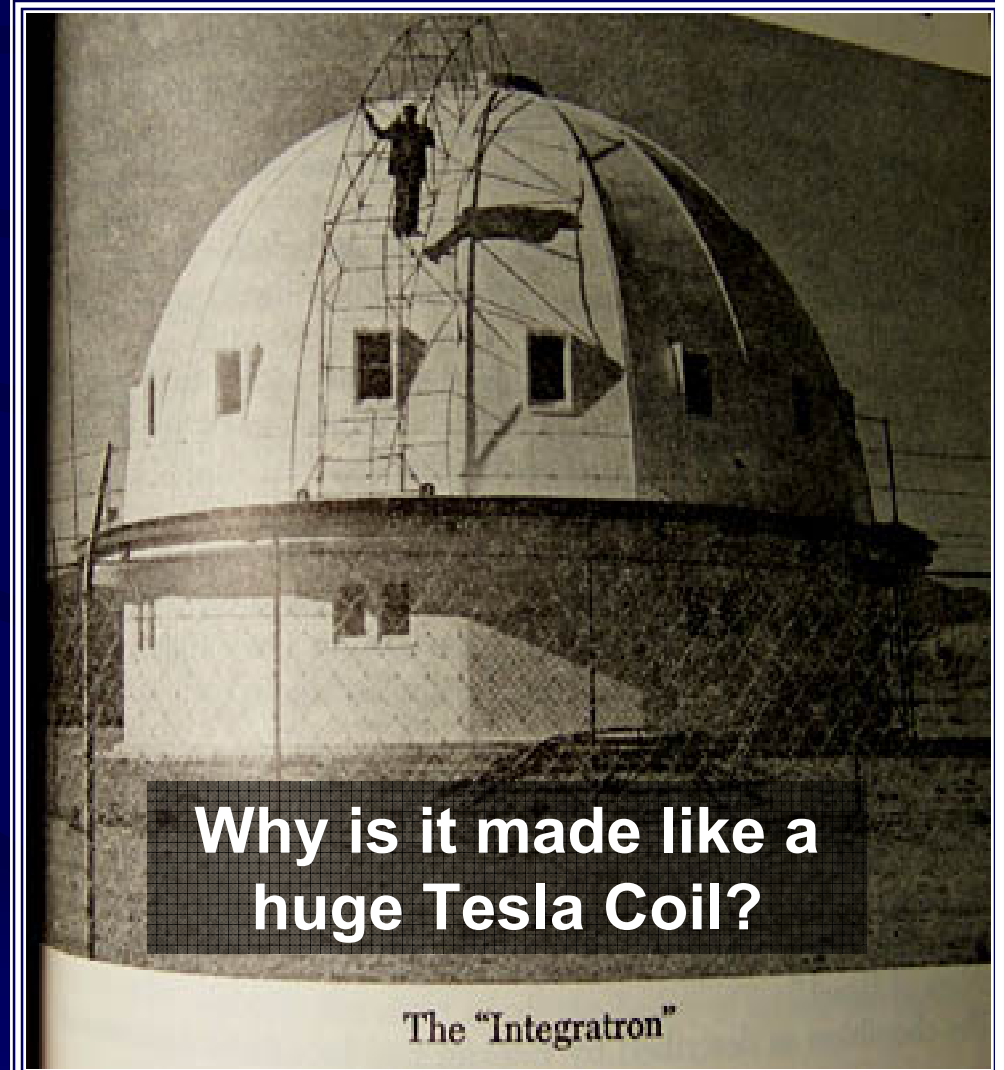

Why is it made like a
huge Tesla Coil?

The “Integratron”

Nikola Tesla

- **Invented Tesla Coil**

- 1896: Niagara Falls - first transmission AC electricity
- 1898 paper: “High Frequency Oscillators for Electrotherapeutic and Other Purposes” using his own Tesla coils at the eighth annual meeting of the

American Electro-Therapeutic Association

- **Physicians responded**

- 1932 Dr. Gustave Kolischer reports:

“Tesla’s HF electrical currents ... highly beneficial results in dealing with cancer.”

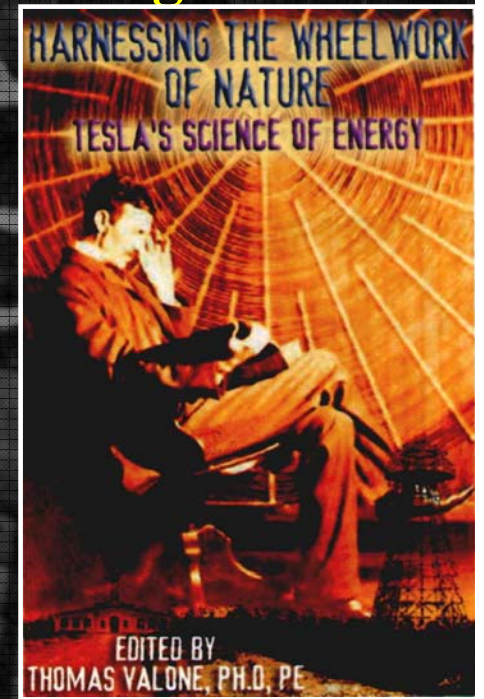

Tesla's HF Electrotherapy Circuits

Published in The Electrical Engineer, 1898

★ = patient's body

Fig. 1

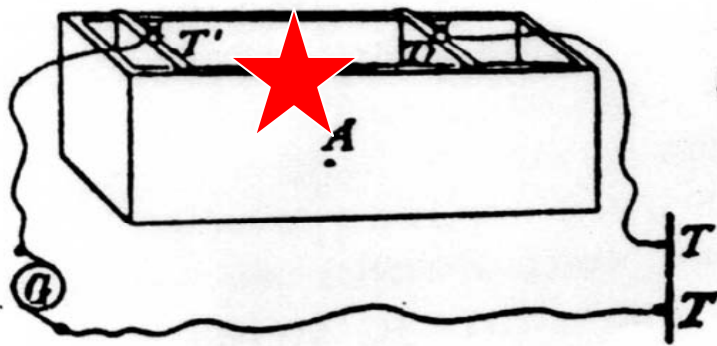

Fig. 2

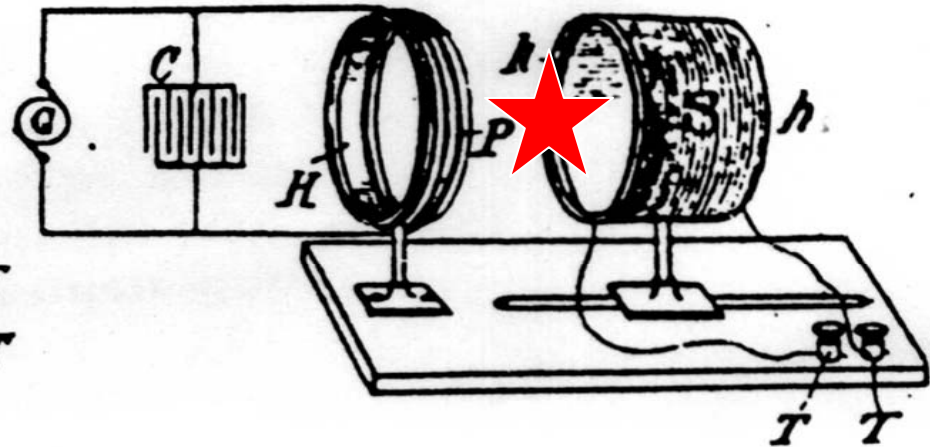

Fig. 5

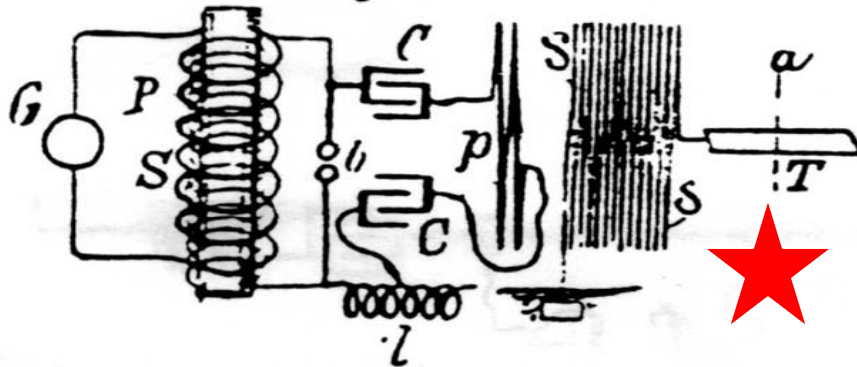
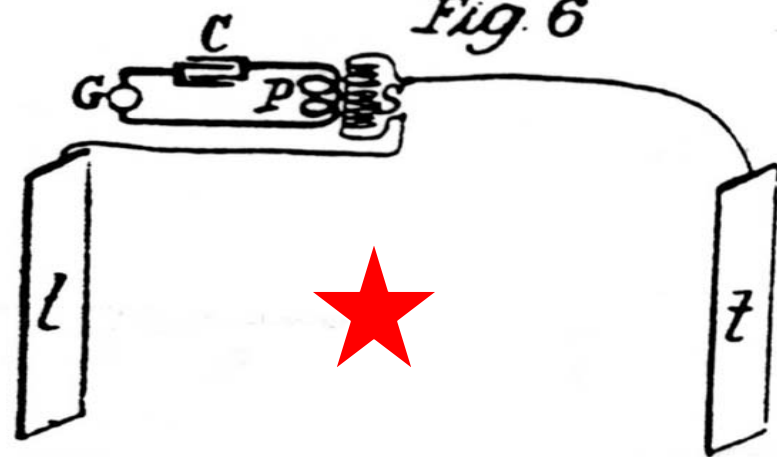

Fig. 6



“Tissues are Condensers”^{*} - Tesla



“The body of a person may be subjected **without danger** to electrical pressures vastly in excess of any producible by ordinary apparatus, for they **may amount to several million volts**, as has been shown in actual practice....will likewise prove to be of value in **electro-therapy.**”

- Nikola Tesla, *The Electrical Engineer*, Nov. 17, 1898

***Condensers** = capacitors that store electrical charge

VACUUM ELECTRODE FILLED WITH A NOBLE GAS



Fig. 354.—Application of vacuum electrode by means of the author's completely insulated handle.

CELL MEMBRANE



1 microfarad/cm²

Animal Plasma Membrane

(Magnified approximately 4.5 million times)

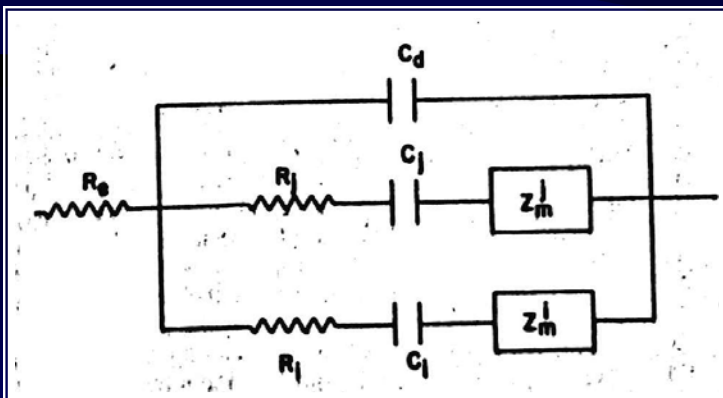

Membrane equivalent circuit

TMP = 100 kV/cm = 10 MV/m

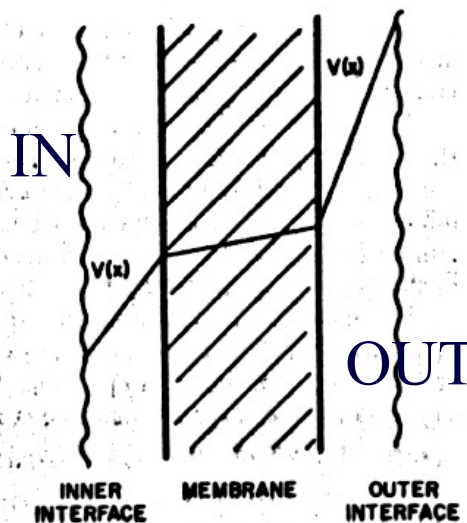

TransMembrane Potential = -70 to -100 mV only in healthy individuals. HV Tesla devices can boost TMP in diseased patients.

Lakhovsky MWO

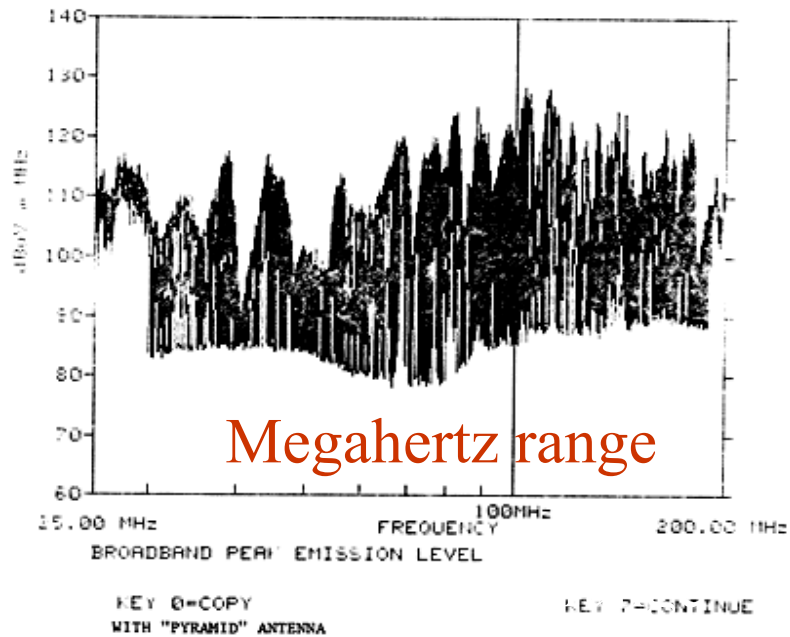

- 1925 *Radio News* - "Curing Cancer with Ultra RF"
- **US Patent #1,962,565**
- 1939 *The Secret of Life*
- 1949 *The Waves that Heal*

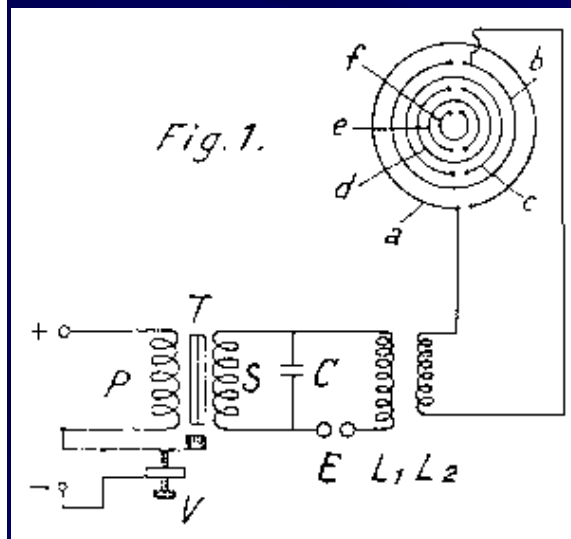
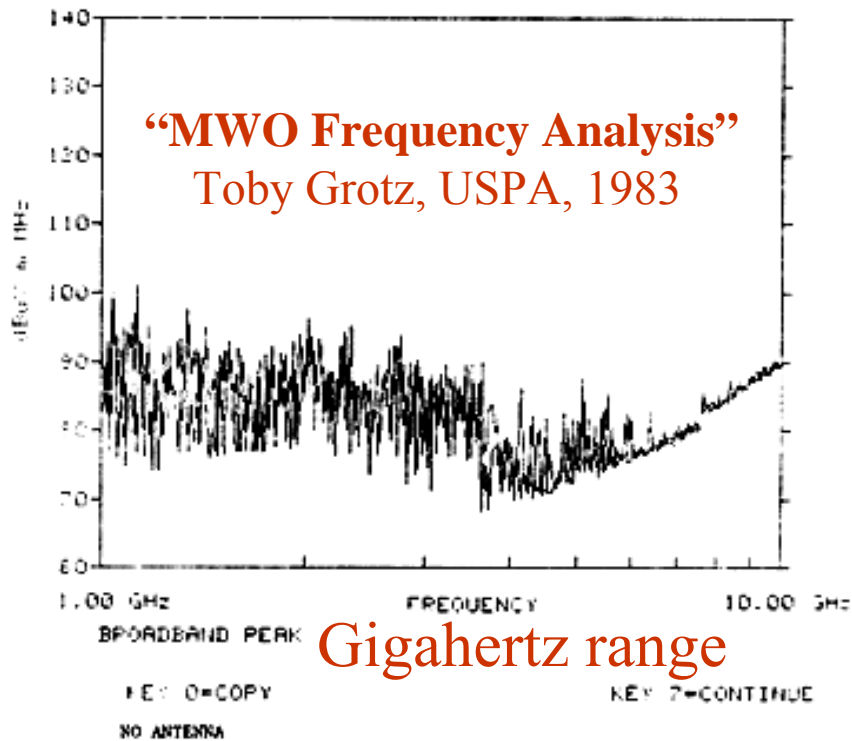

Electrons are Antioxidants

FREE RADICALS STEAL ELECTRONS

creating more free radical DAMAGE in a chain reaction (10,000 times)

Damaged mitochondrial DNA causes aging

ANTIOXIDANTS STOP FREE RADICALS WITH ELECTRONS

References

- **“Oxidative damage causes aging”** - *Life Enhancement*, Oct. 2004
- “Dying before their time: studies of prematurely old mice hint that DNA mutations underlie aging.” *Science News*, July 10, 2004, p. 26
- “Mice and mitochondria” Martin, *Nature*, 2004, V. 429, p. 357,417

Electromagnetic HV Energy Medicine

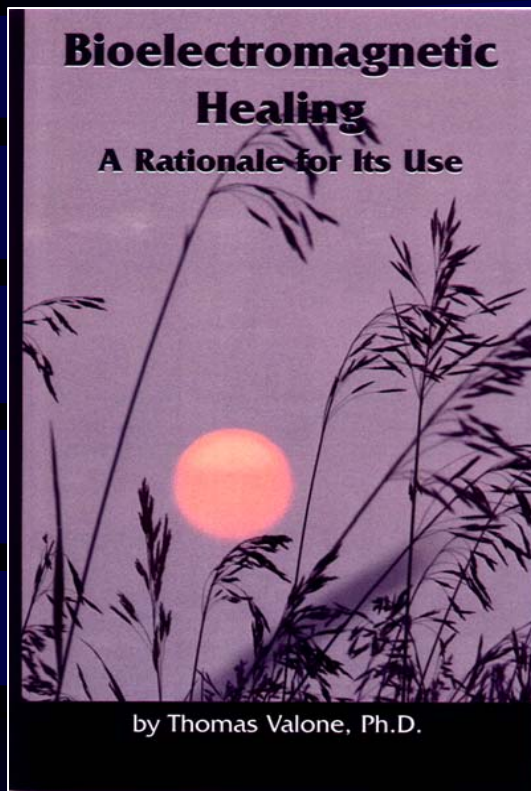

- HF EMF penetrate several centimeters into body
- Diseased cells = low **transmembrane potential**
- Low TMP = low Na-K pump & ATP impairment
- Membranes rectify AC so DC electrons flow
- **External HV EMFs can also increase TMP**
- Boosting TMP and creating electron transfer to **fight free radicals** helps the immune system
- Electrons are any antioxidant's active ingredient

**Short term exposure to HV electricity
strengthens immune response**

Photonic Rejuvenation Energizing Machine & Immunizing Electrification Radiator (PREMIER)



**Dr. Richard Gerow
with Model 200**

Feel Always Energized

PREMIER 100

**Bestselling
bioenergy
machine that
produces
electronic
antioxidants
to fight free
radicals***

** Bioelectromagnetic
Healing: A Rationale for its
Use, 9th ed., p. 86, 2008*

*"After one treatment
and 7 hours of driv-
ing, I still had energy
to burn." - Susan R.
"I love my Model
200!" - Gene D.*



**The Photonic Rejuvenation
Energizing Machine &
Immunizing Electrification
Radiator (PREMIER)**

JUST \$495

**888-802-5243 301-220-0440
Email: iri@starpower.net**

IntegrityResearchInstitute.org



**Dr. Jacqueline
Panting
using Model 2500**

Energy Chair

IRI Bioenergetics Project

- Recreation of the Autocondensation Couch in a more compact form

- See “Tesla” book by Margaret Cheney

- HV broadband PEMFs

- Whole body TMP boost

- Debut at Whole Person Healing Conference 2005

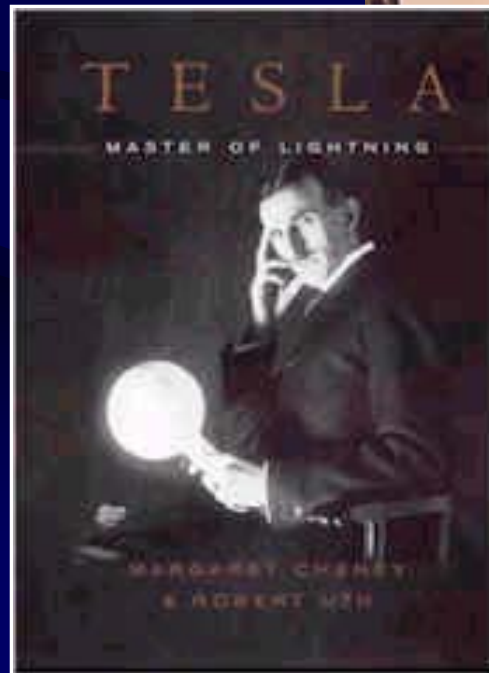

Yogis Say Electricity Can Heal Body



**“Electricity and rays
are finer in nature
than solids or
liquids, and
therefore a more
subtle force for
healing.”**

Paramahansa Yogananda
author of *Autobiography of a Yogi*,
circa 1940 - *Self-Realization*,
Winter, 2003 issue

**And only 3 Miles from the
Integratron is GIANT ROCK,
a link to the
2nd IRI UFO Project:**

**Permanent Magnet
Motors**

Sunburst: Return of the Ancients

By Norman Paulsen

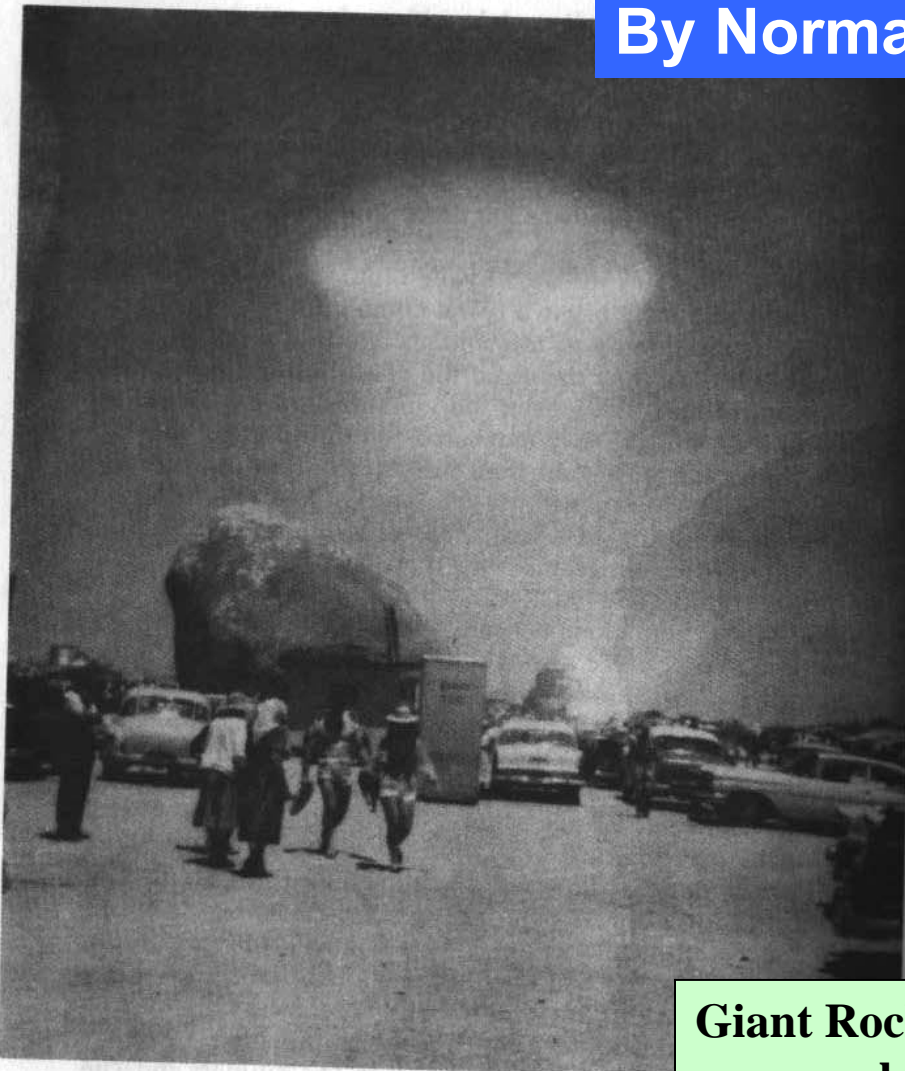

A ship over Giant Rock,

**Giant Rock, Calif.
saucer, photo, &
deputy sheriff who
took the photo**

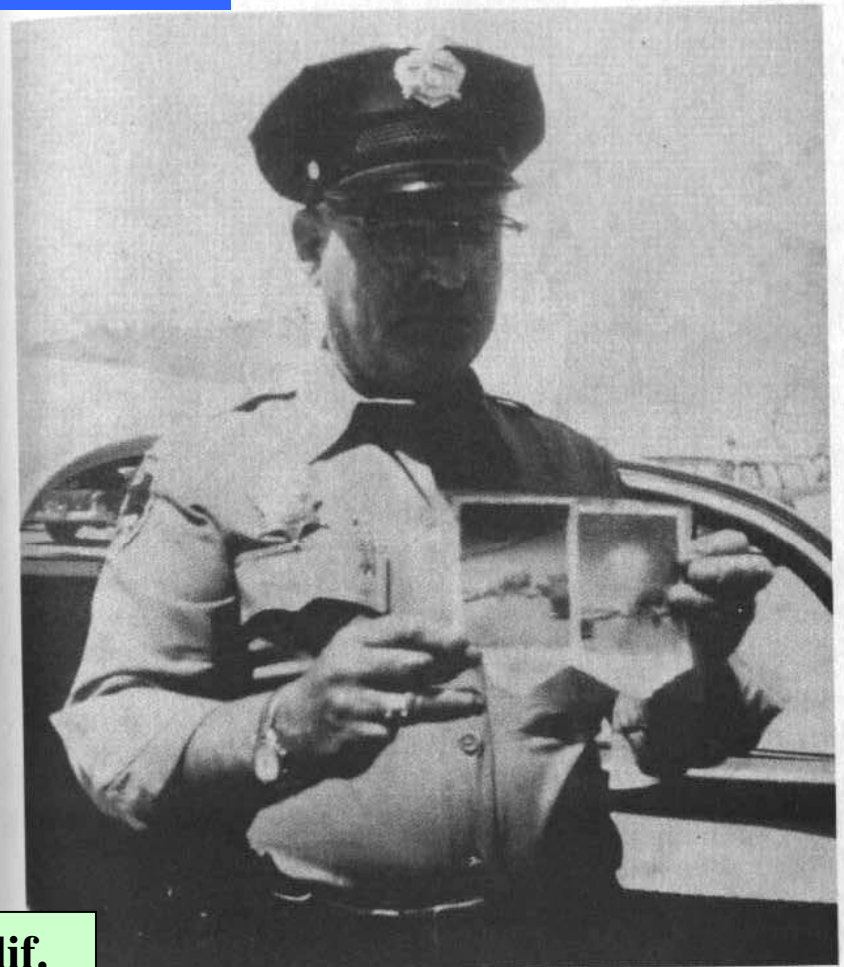

And the deputy sheriff who took the picture.

“The outside perimeter of each disc carries **twelve magnets**...Here we can draw off electrical current from the central hubs on which they spin...The generation of a **perpetual flow of electrical energy** from each disc will continue as long as the discs rotate...this magnetic and gyroscopic effect **creates its own gravity.**” --

Ancient Elder on Mu Ship

(*Sunburst* book, reprinted in ***Homopolar Handbook***)

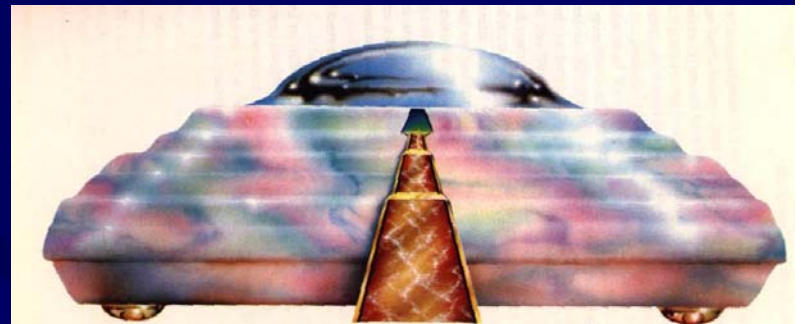

Homopolar Generators are “a subject worthy of further research”

THE HOMOPOLAR HANDBOOK

A Definitive Guide to Faraday Disk and N-Machine Technologies

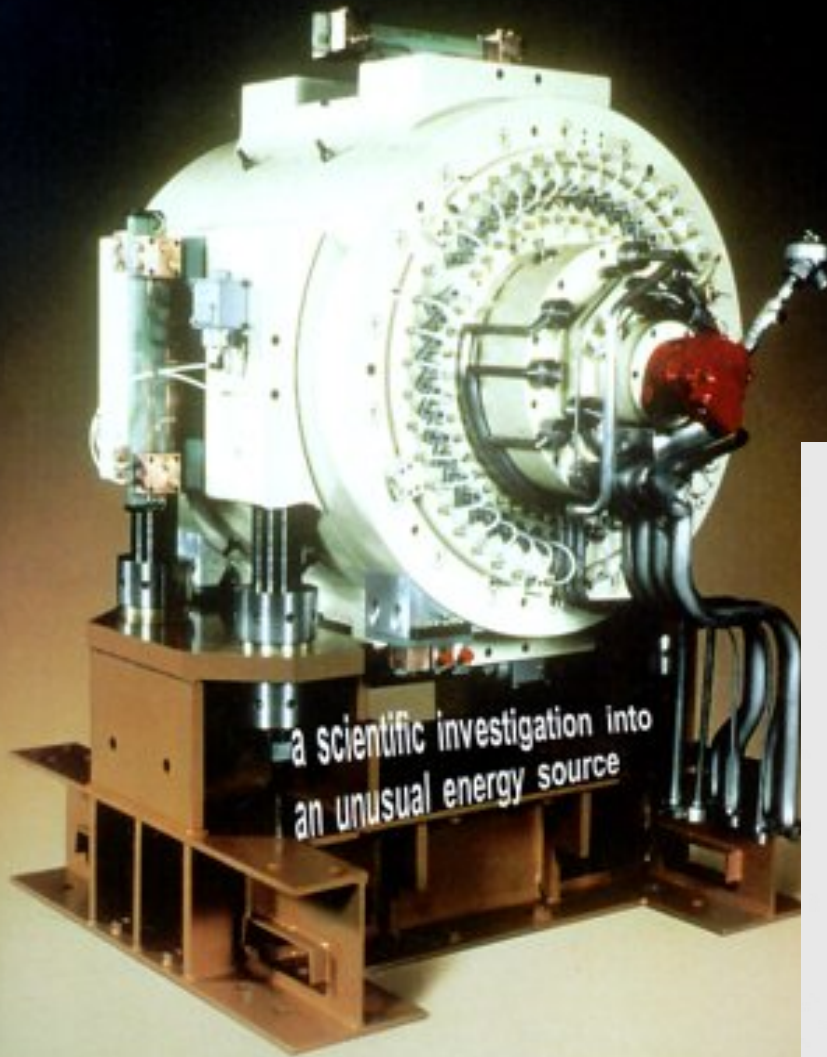

Thomas Valone, M.A., P.E.
Foreword by Gary L. Johnson, Ph.D.

Based on *Sunburst: Return of the Ancients* book by Norman Paulsen:

“generator would be self-perpetuating”

“12 magnets around the edge of a rotating disk”

My homopolar generator

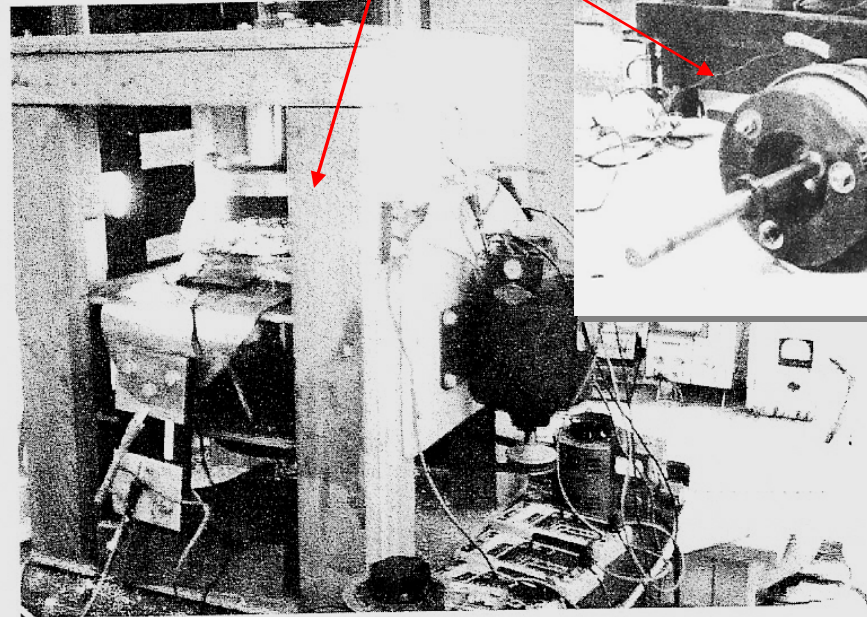

Figure 12. Homopolar generator - rotating.
Square wave on Oscilloscope is the photocell circuit output.

Vol. VI

Issue 2

1994

Astronaut

**Dr. Edgar
Mitchell**

Considered
investing in
the DePalma
homopolar
generator
in 1980

\$8.95 • ISSN 1043-3716 • Volume VI • Issue 2 • Apr. May Jun. 1994

EXTRAORDINARY *Science*

SYMPOSIUM EDITION

- **A FREE ENERGY DEVICE**
Dark Secrets of the N-Machine
- **ANTI-GRAVITY**
The Dream Made Reality
- **SUPER STEAM TECHNOLOGY**
Powering the 21st Century

*The Truth, the Whole Truth...
& Nothing but the Truth*

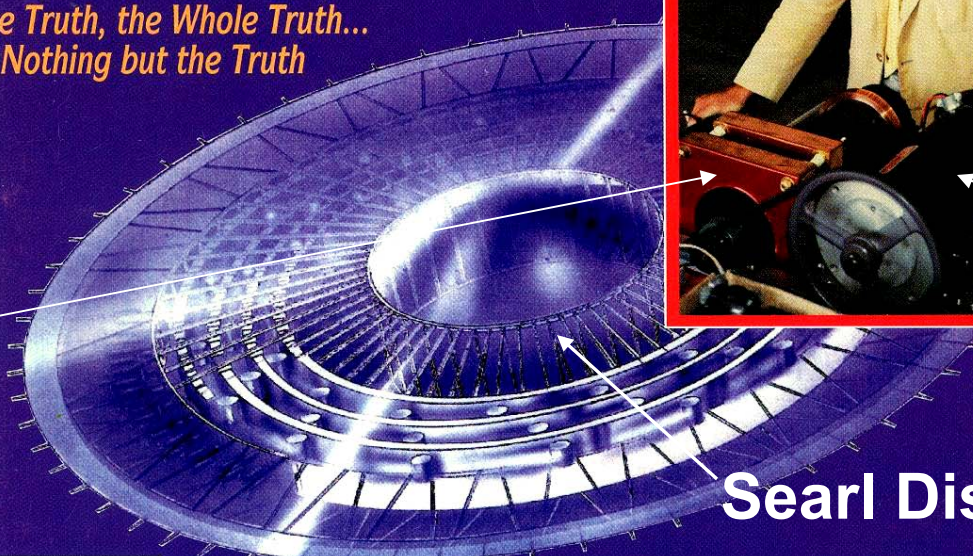
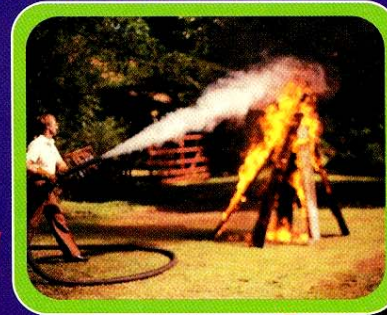

Edgar

\$\$\$

motor

Searl Disk drawing



The Official Magazine of the International Tech Society



SEARL INTERNATIONAL SPACE RESEARCH CONSORTIUM

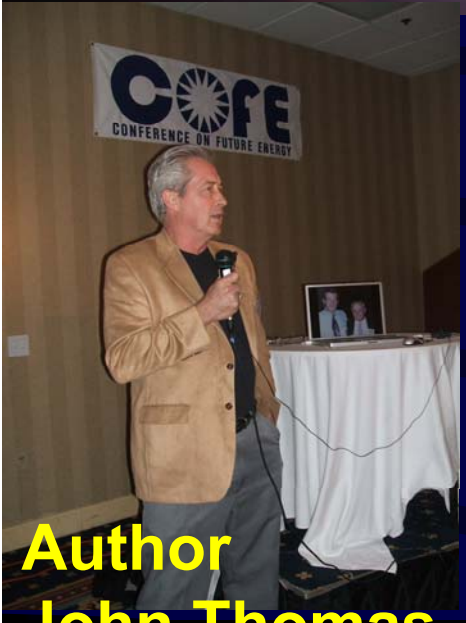

Author
John Thomas

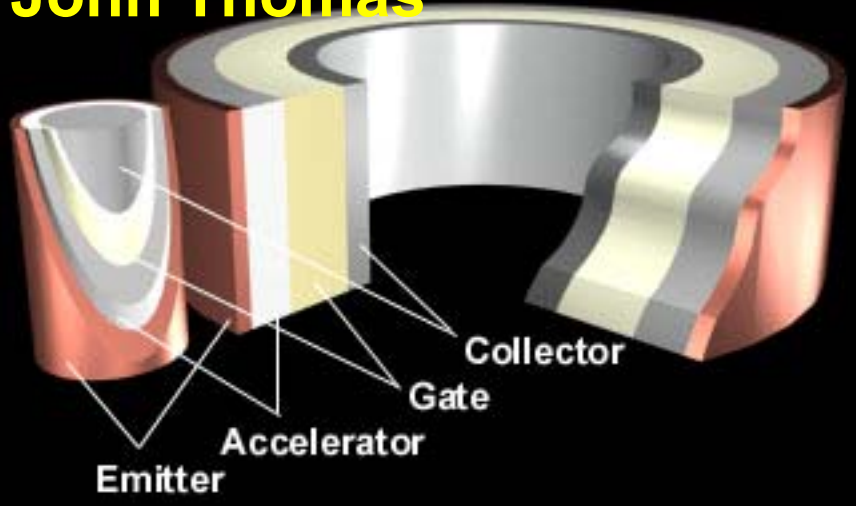
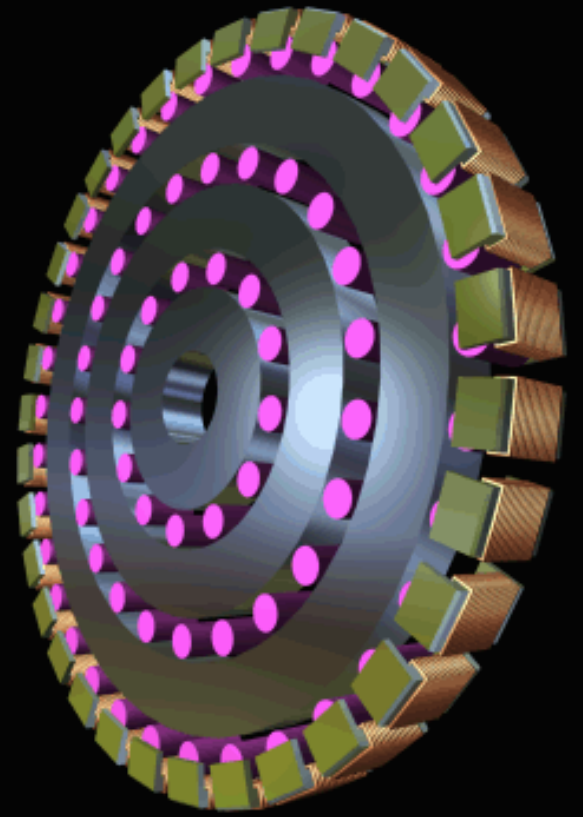
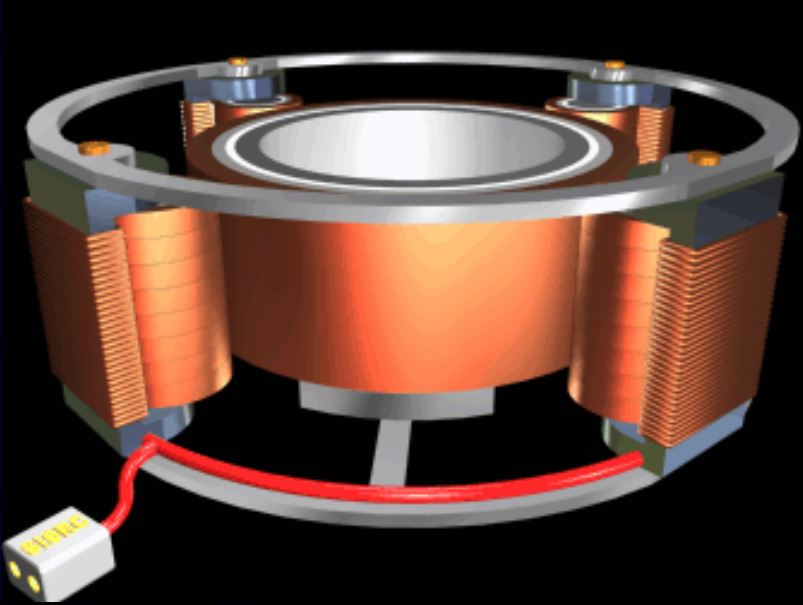

**Searl Disk
Allegedly Provides
Force and Power**

John R. R. Searl

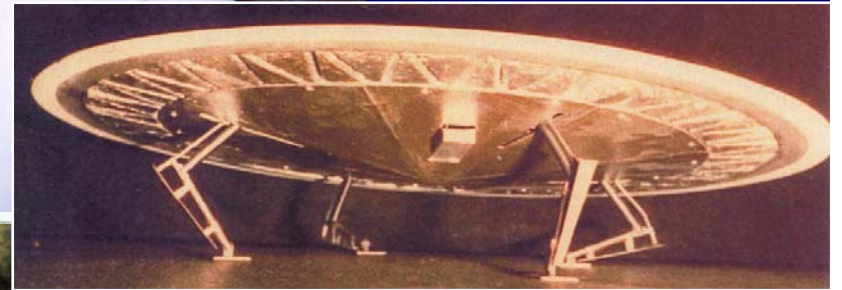

A Possible Embodiment of the Paulsen Mu Disc is the Searl Disk and the MEC

MEC

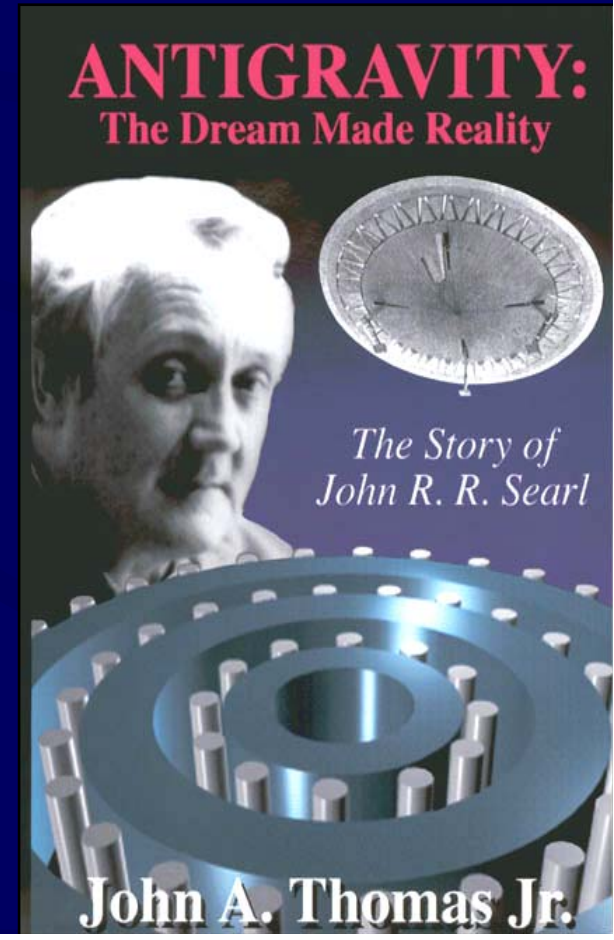
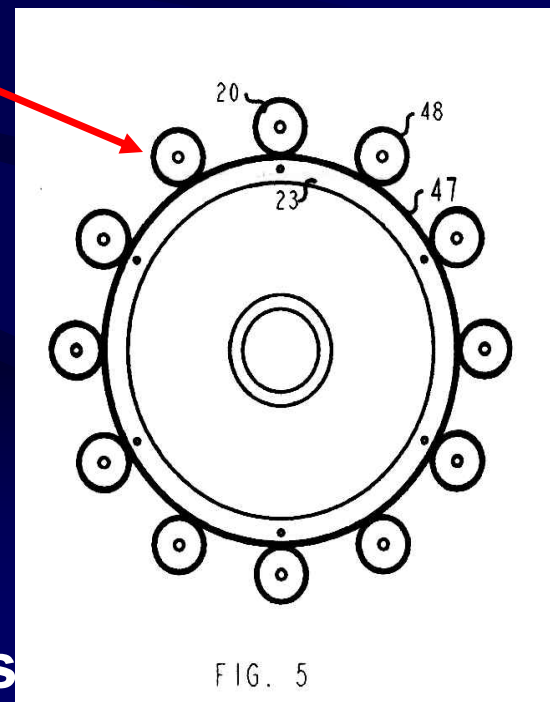
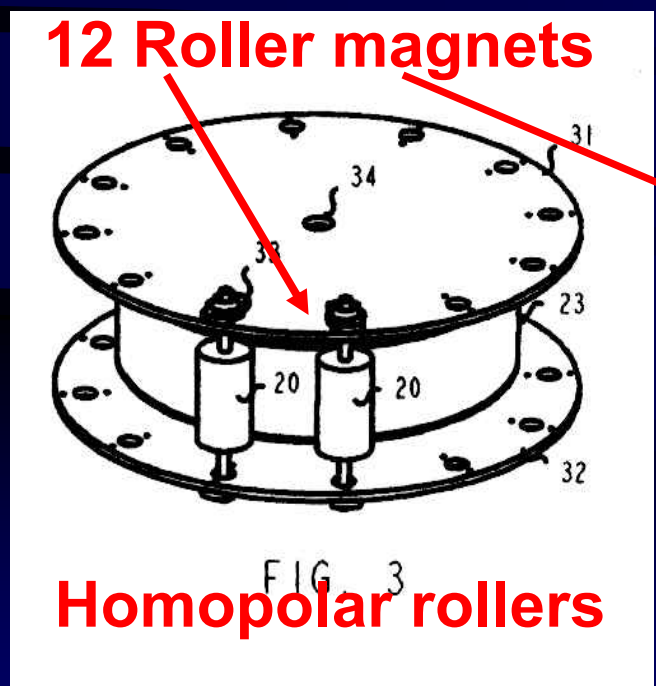

Designed by 2 Russians

Orbiting Homopolar Magnetic Energy Converter

US Patent 6,822,361 drafted by
Valone

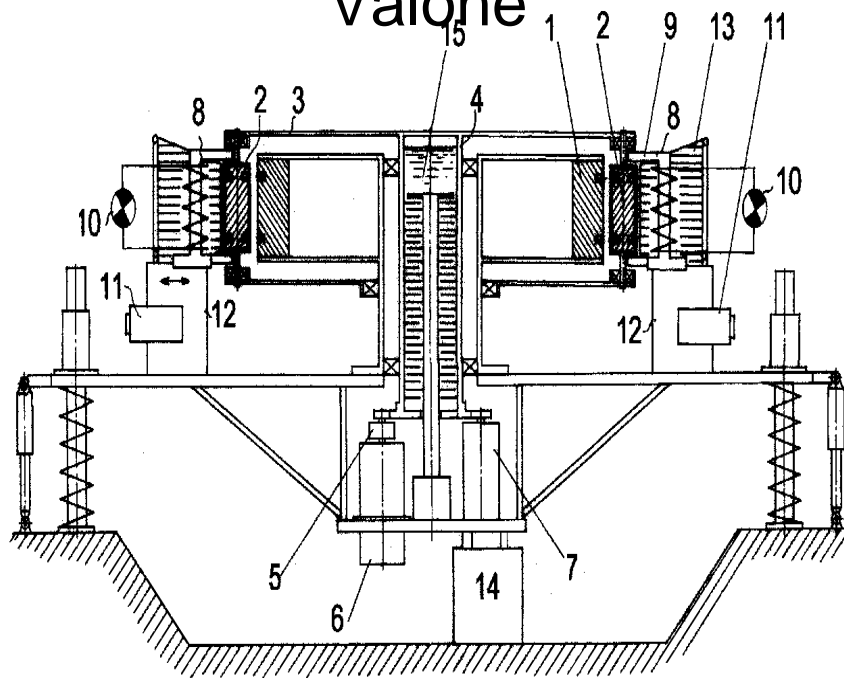

Energy & Propulsion Systems, LLC Exponential speed increase

- V. Roshchin & S. Godin
- 7 kW power generation
- 100 kW capability
- 35% weight reduction or amplification at 550 rpm.
- Spatial magnetic field increase (50 mT) coaxially
- 7° C (13 ° F) temperature drop up to 15 meters away
- Improved efficiency with 20 kV applied high voltage
- Exponential speed increase

The Russian MEC Inventors, Godin and Roshchin at the US Dept. of Energy (USDOE)

I am
here



MEC Prototype Being Completed in Russia

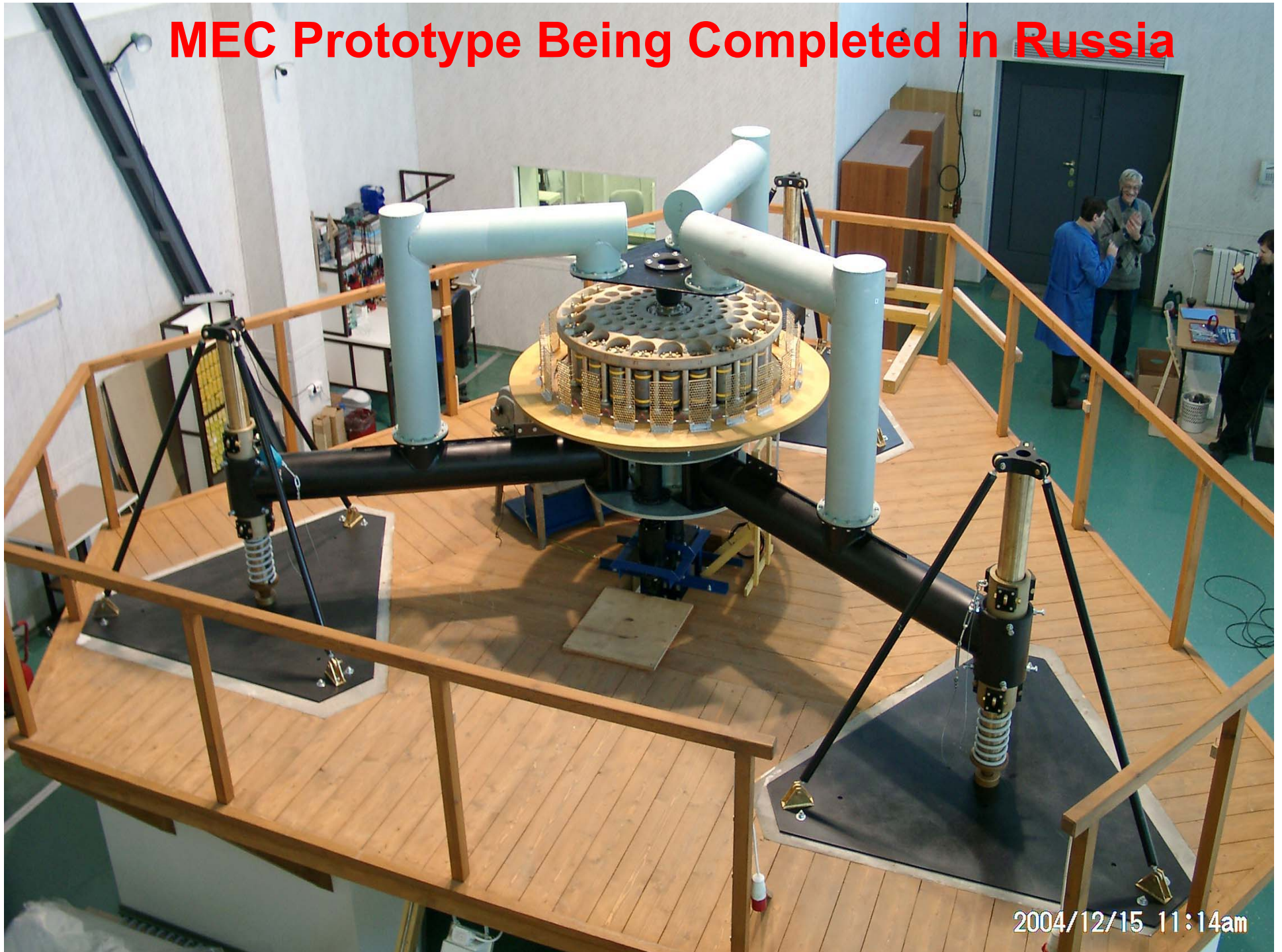

2004/12/15 11:14am

Spiral Magnetic Motor Utilizes Magnetic Gradient

- **Magnetic rotor** repelled from spiral **Stator Magnet** causing **Torque**
- **EM Pulse** sends the **Rotor Magnet** past the magnetic field gap to begin the revolution again.
- **Magnetic Gradient** is source of force
- Japanese “**Magnetic Wankel**” Kure Tekkosho Company in Pop. Sci., 1979

Inhomogeneous magnetic fields ($dB/d\theta$) create the **circumferential force (F)**

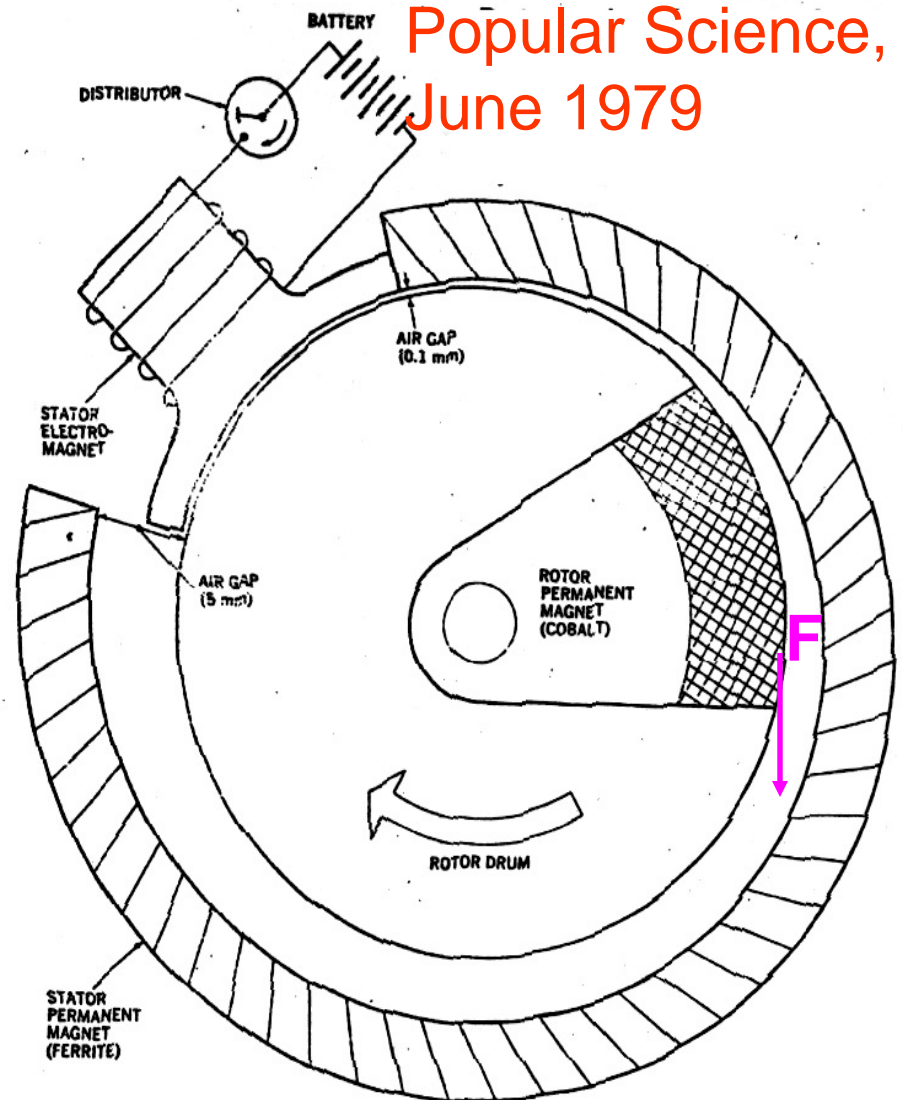

Inhomogeneous Magnetic Fields

The Stern–Gerlach Experiment and Electron Spin

Modern Physics, Schaumm's Outline Series, Gautreau , McGraw Hill, 1978

In the *Stern–Gerlach experiment*, performed in 1921, a beam of silver atoms having zero total orbital angular momentum passes through an *inhomogeneous* magnetic field and strikes a photographic plate, as shown in Fig. 21-1. Any deflection of the beam when the magnetic field is turned on is measured on the photographic plate.

Their experimental setup: The magnetic field B is more intense near the pointed surface at the top than near the flat surface below, creating a slope in a graph of B vs. z , which is the gradient dB/dz .

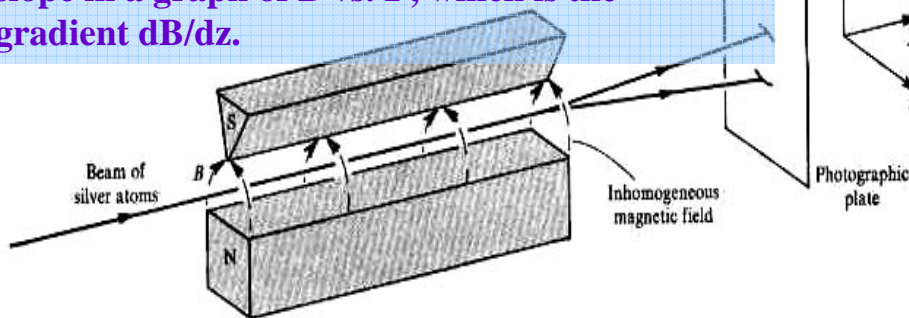

Fig. 21-1

The purpose of the *inhomogeneous* magnetic field is to produce a deflecting force on any magnetic moments that are present in the beam. If a homogeneous magnetic field were used, each magnetic moment would experience only a torque and no deflecting force. In an inhomogeneous magnetic field, however, a net deflecting force will be exerted on each magnetic moment μ_z . For the situation of Fig. 21-1,

$$F_z = \mu_z \cos \theta \frac{dB}{dz} \quad (21.1)$$

where θ is the angle between μ_z and B , and dB/dz is the gradient of the inhomogeneous field

Top View

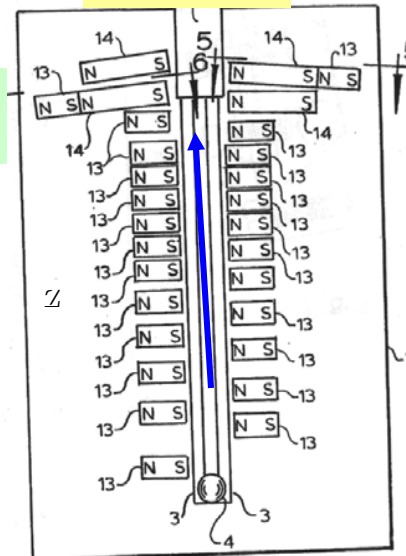

The net Force created on the ball bearing = the magnetic field gradient multiplied by the induced magnetic moment, as with the Stern–Gerlach Experiment

Hartman Patent #4,215,330

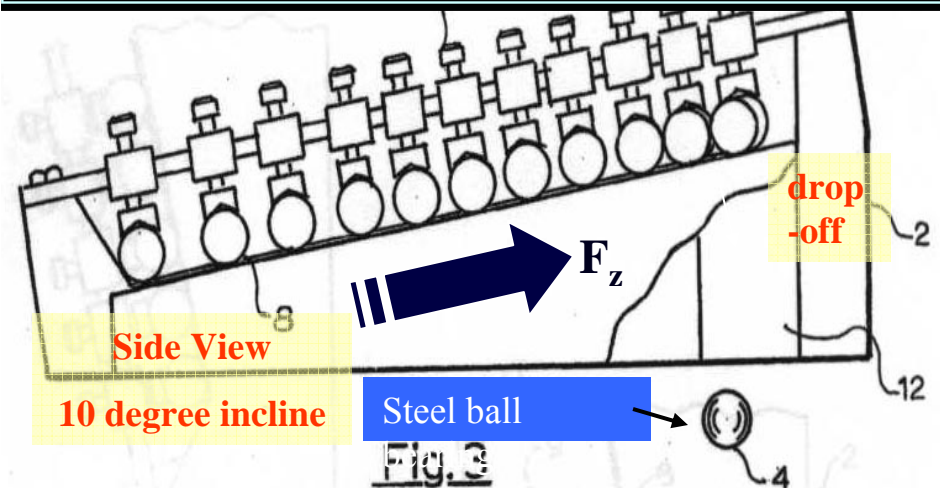

Side View

10 degree incline

Steel ball

Fig. 3

Spiral Motor with and without an Electromagnet Switch

H. Paul Sprain
patented motor

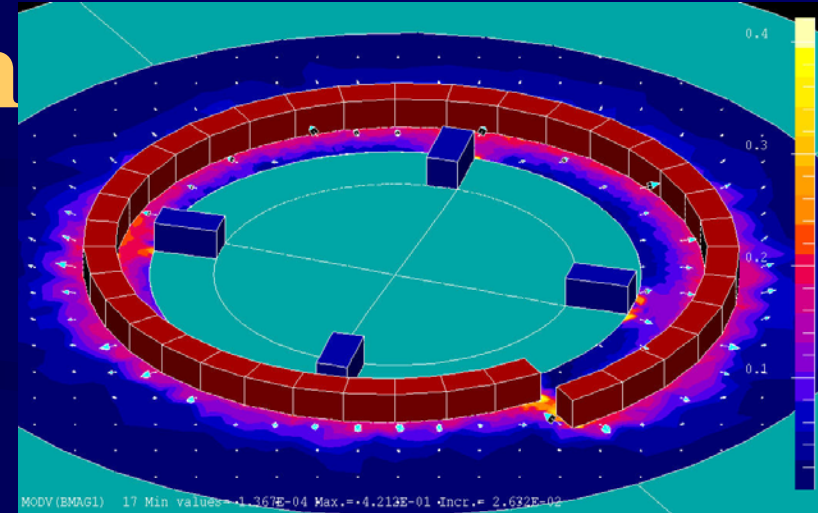

IRI Spiral Wankel Motor design
with a Weigand-GMM-PZT
switch and no external
electricity

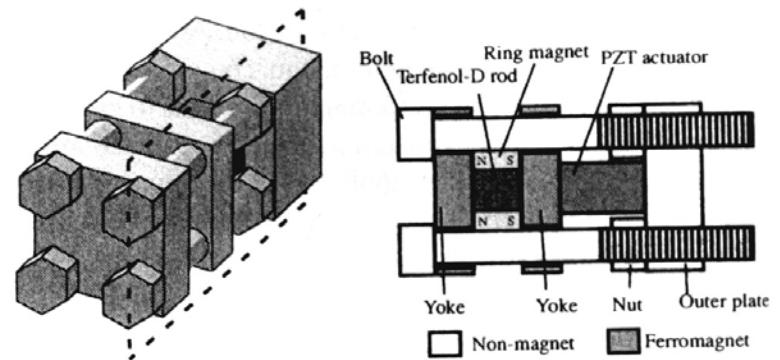

Mike Brady's Magnetic Motor

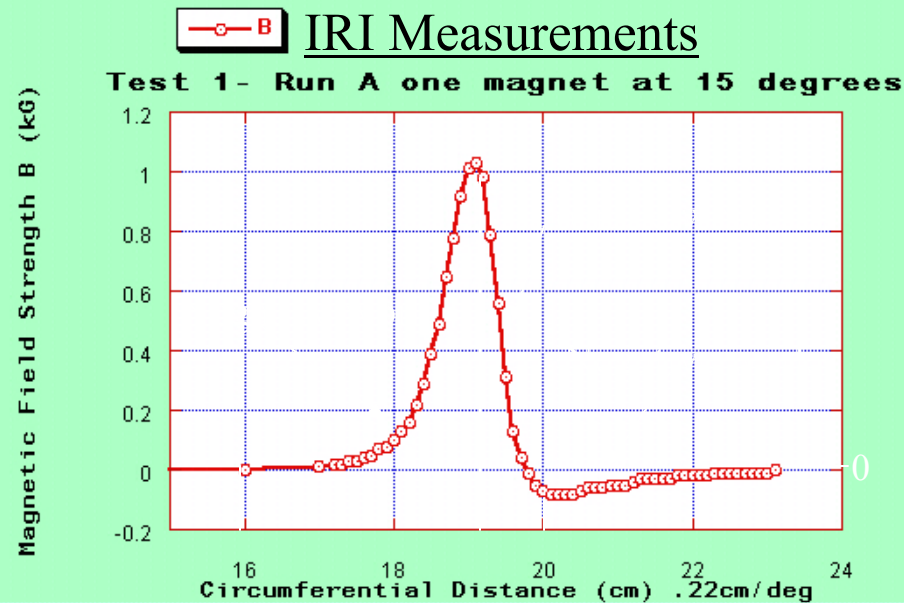

Asymmetric gaussmeter data plot

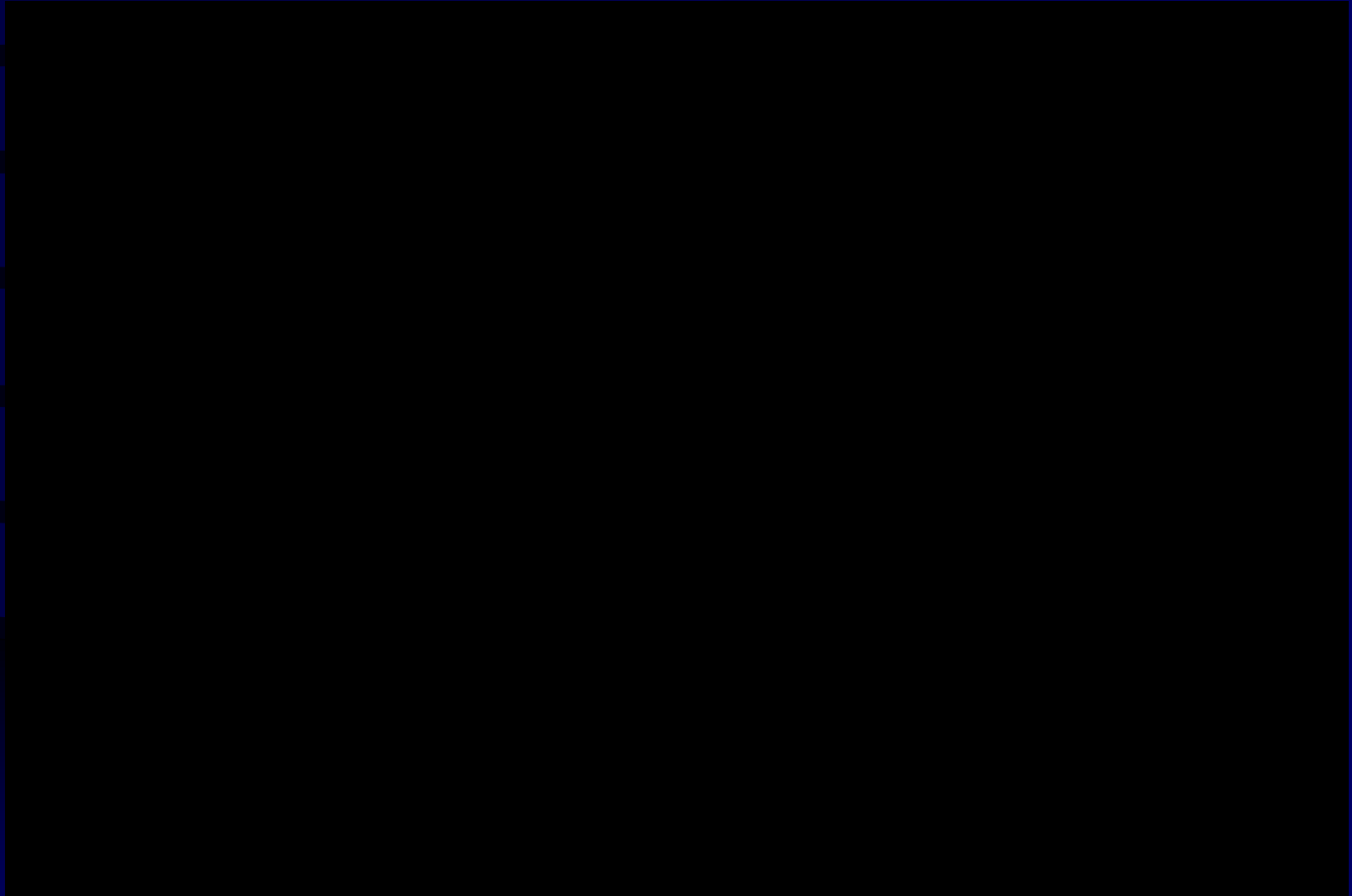

Image from video, www.perendev-power.com

- All-magnetic design
- Unique magnet alignment
- 3500 RPM operation
- 20 kW delivery claimed
- Uses NdFeB magnets
- Public domain invention
- Does not provide sustained operation

Show →
TV clip

Video Clip from Discovery Channel



Introduction to Zero Point Energy

3rd Project: The Quantum Vacuum



Quantum fluctuations of the vacuum create virtual particles (real for an instant) that produce shielding & mechanical force

- **Zero-point energy** is not conserved (open system)
- Helium stays liquid $< 1^\circ\text{K}$
- ZPE density = 220 erg/cc in optical region (ref. Milonni)



Koltick electron experiment

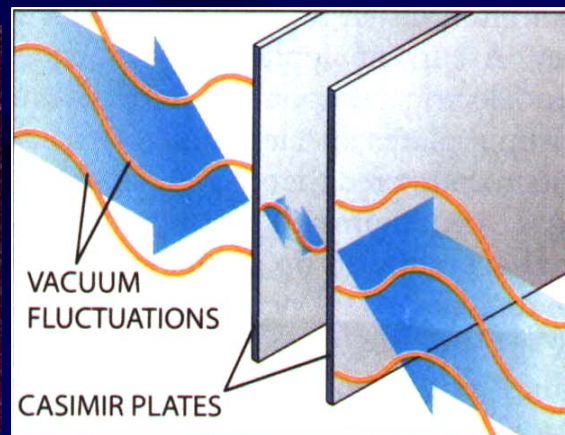

Casimir force pushes

Electron-positron production

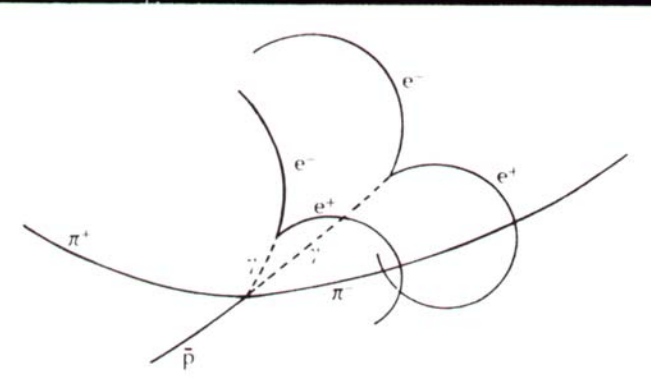

Zero Point Energy

(Emerging science, 1948...)

What?

- Random Electromagnetic waves remain after all energy is removed
- Enormous energy density: 10^{24} to 10^{58} Joules/m³
- Theorized to indirectly cause gravity and inertia

Why?

- As an energy source?
- As a reactive medium?

Evidence?

- Casimir Effect
- Plank blackbody spectrum
- quantum effects

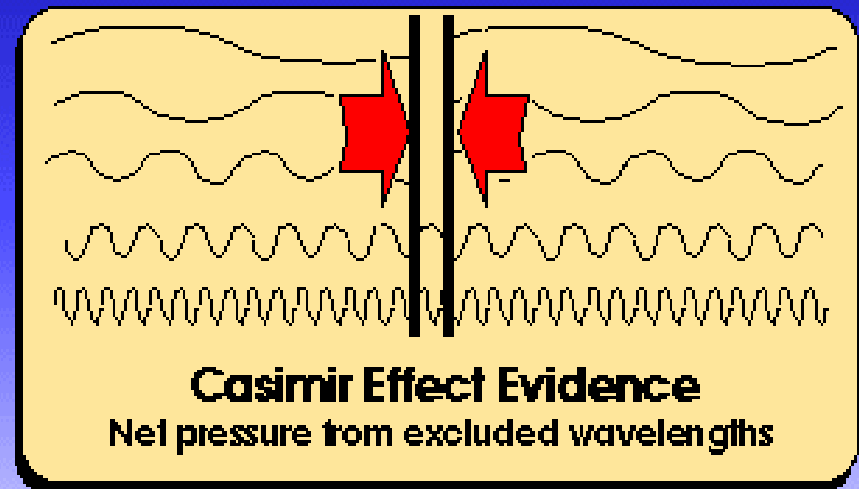

Rectifying Thermal and Non-Thermal Electric Noise

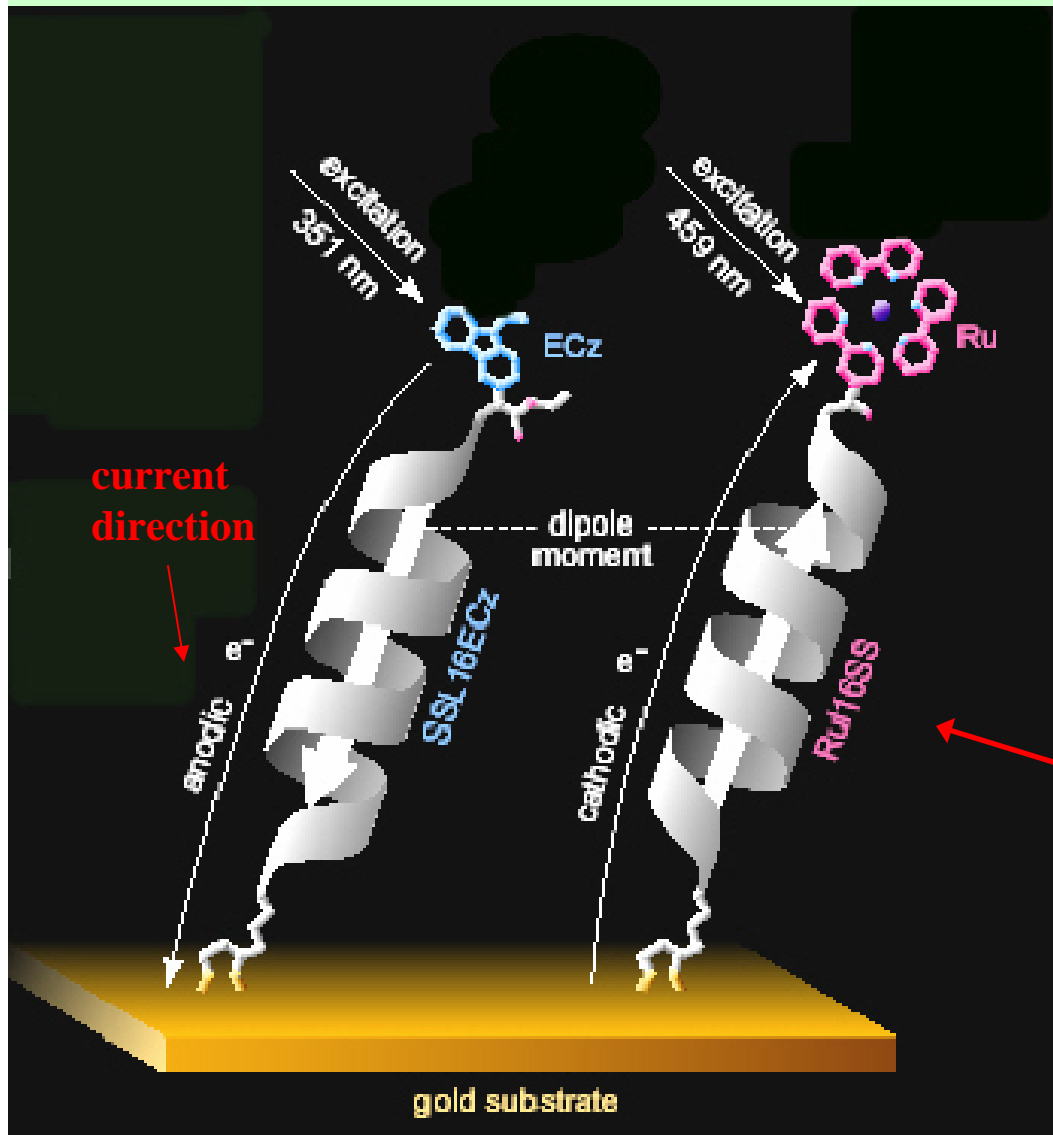

- Brown #3,890,161
- Zero-bias diode arrays

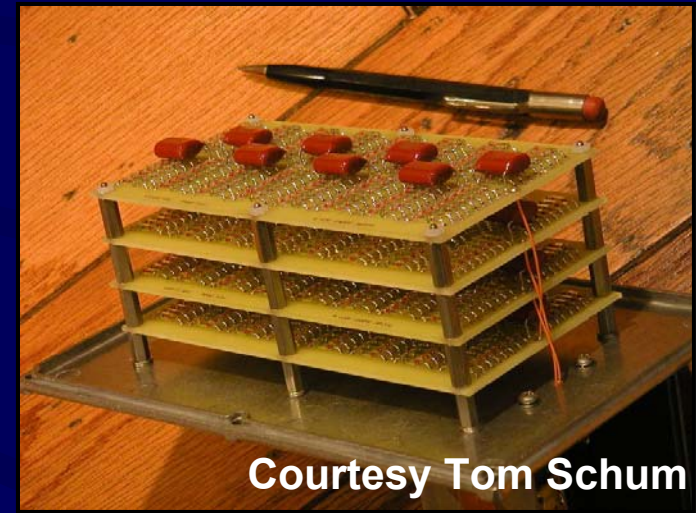

- Peptide molecular photodiodes 1 nm across

Yasutomi et al. 2004 *Science* 304
1944



Dr. Pinto's Casimir Engine

50 - 100 microns

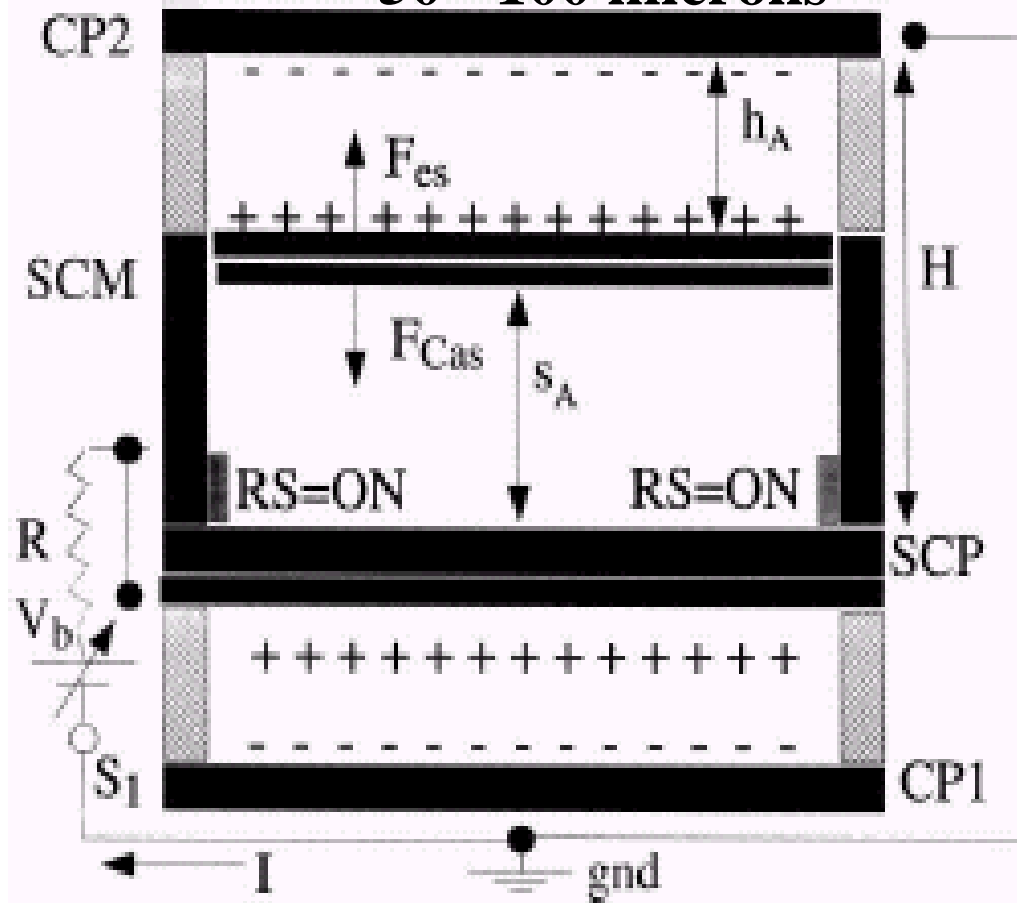

- Uses microlasers (RS)
- Similar to Forward's "parking ramp"
- Movable and fixed
- optically controlled vacuum energy transducer @ 10 kHz
- **Power = 0.5 nW**
- 10 microjoules/cm² for every cycle
- *Physical Review B*

Pinto, Phys. Rev.B, 60, 21, 1999, p.4457

Feasibility of ZPE Extraction Study

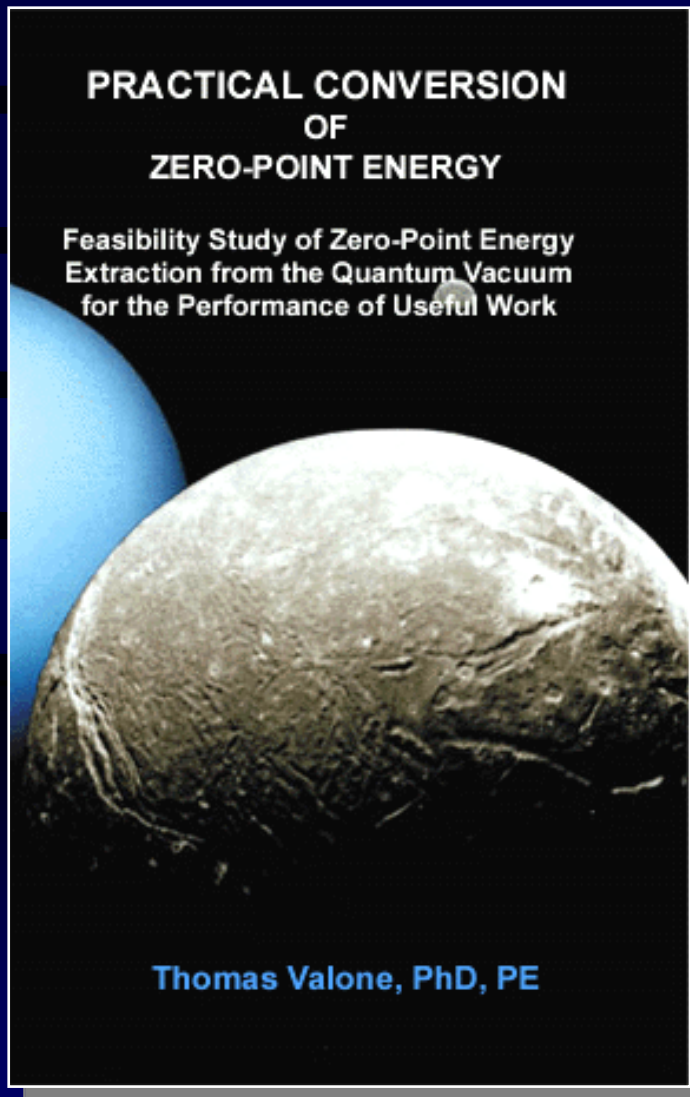

Feasibility ZPE Study

Zero Point Energy Extraction from the
Quantum Vacuum for the Performance
of Useful Work

Author: Integrity Research Institute
T. F. Valone, Ph.D. 1220 L St. NW, Suite 100-232
Washington, DC 2005

Approved for Public Release

Distribution is unlimited. The Board of Directors of Integrity Research Institute has reviewed this report, and it is releasable to distributors and to the general public, including foreign nationals.

Thomas Valone, PhD
Thesis:

Kennedy-Western
University (Warren
National), Sept., 2003

Websites:

www.IntegrityResearchInstitute.org

www.quantumfields.com

www.zpenergy.com

www.earthtech.org

Science Times

The New York Times

Jan 21, 1997

TUESDAY, JANUARY 21, 1997

Physicists Confirm Power of Nothing, Measuring Force of Quantum 'Foam'

Fluctuations in the vacuum are
the universal pulse of existence.

By MALCOLM W. BROWNE

FOR a half century, physicists have known that there is no such thing as absolute nothingness, and that the vacuum of empty space, devoid of even a single atom of matter, seethes with subtle activity. Now, with the help of a pair of metal plates and a fine wire, a scientist has directly measured the force exerted by fleeting fluctuations in the vacuum that pace the universal pulse of existence.

The sensitive experiment performed at the University of Washington in Seattle by Dr. Steve K. Lamoreaux, an atomic physicist who is now at Los Alamos National

Laboratory, was described in a recent issue of the journal *Physical Review Letters*. Dr. Lamoreaux's results almost perfectly matched theoretical predictions based on quantum electrodynamics, a theory that touches on many of the riddles of existence and on the origin and fate of the universe.

The theory has been wonderfully accurate in predicting the results of subatomic particle experiments, and has also been the basis of speculations verging on science fiction. One of the wilder ones is the possibility that the universal vacuum — the ubiquitous empty space of the universe — might actually be a false vacuum.

If that were so, something might cause the present-day universal vacuum to collapse to a different vacuum of a lower energy. The effect, propagating at the speed of light, would be the annihilation of all matter in the universe. There would be no warning for humankind; the earth and its inhabitants would simply cease to exist at

Continued on Page C6

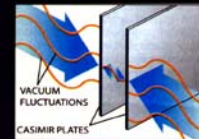
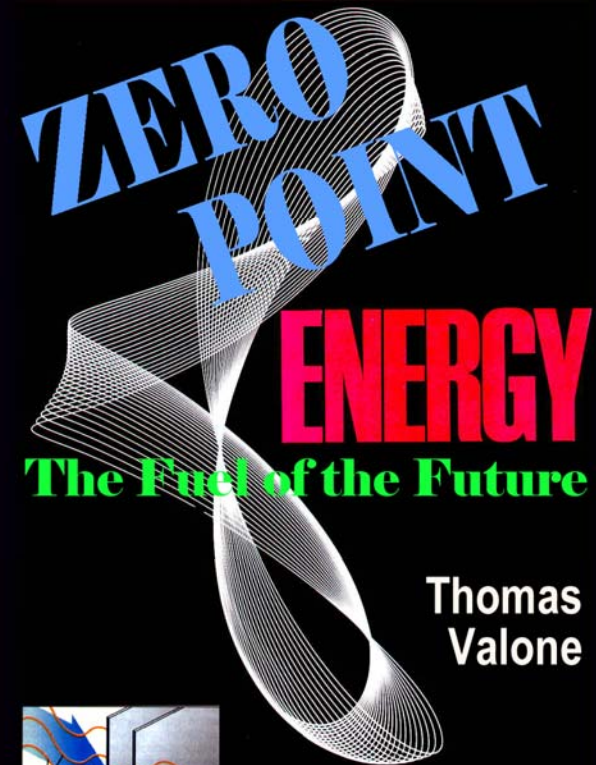

PROPULSION



4th Project

Betty & Barney Hill 1961 UFO Story

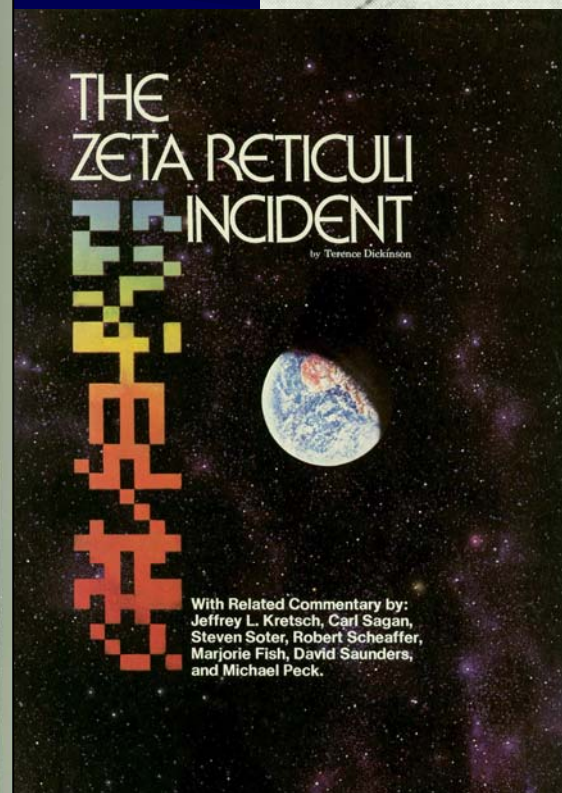
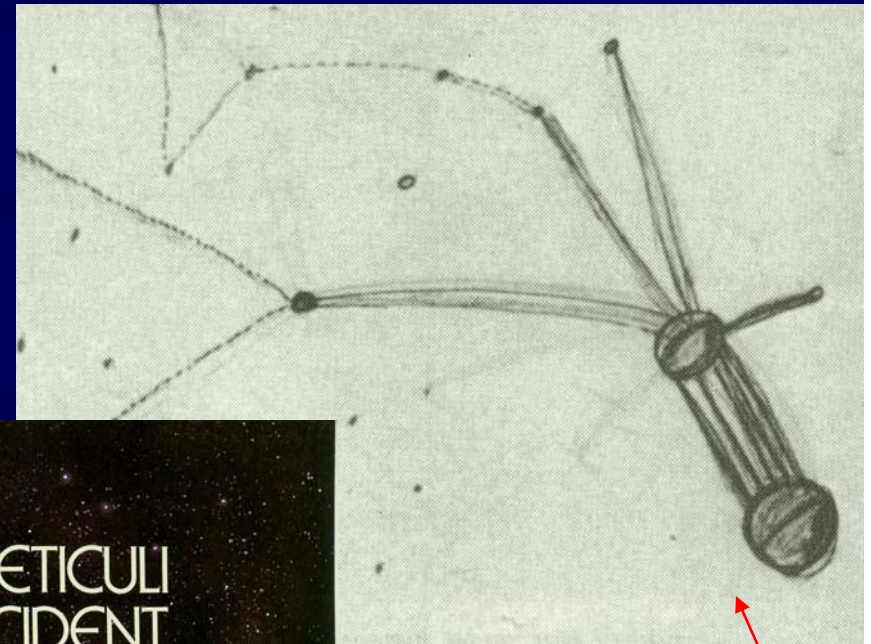
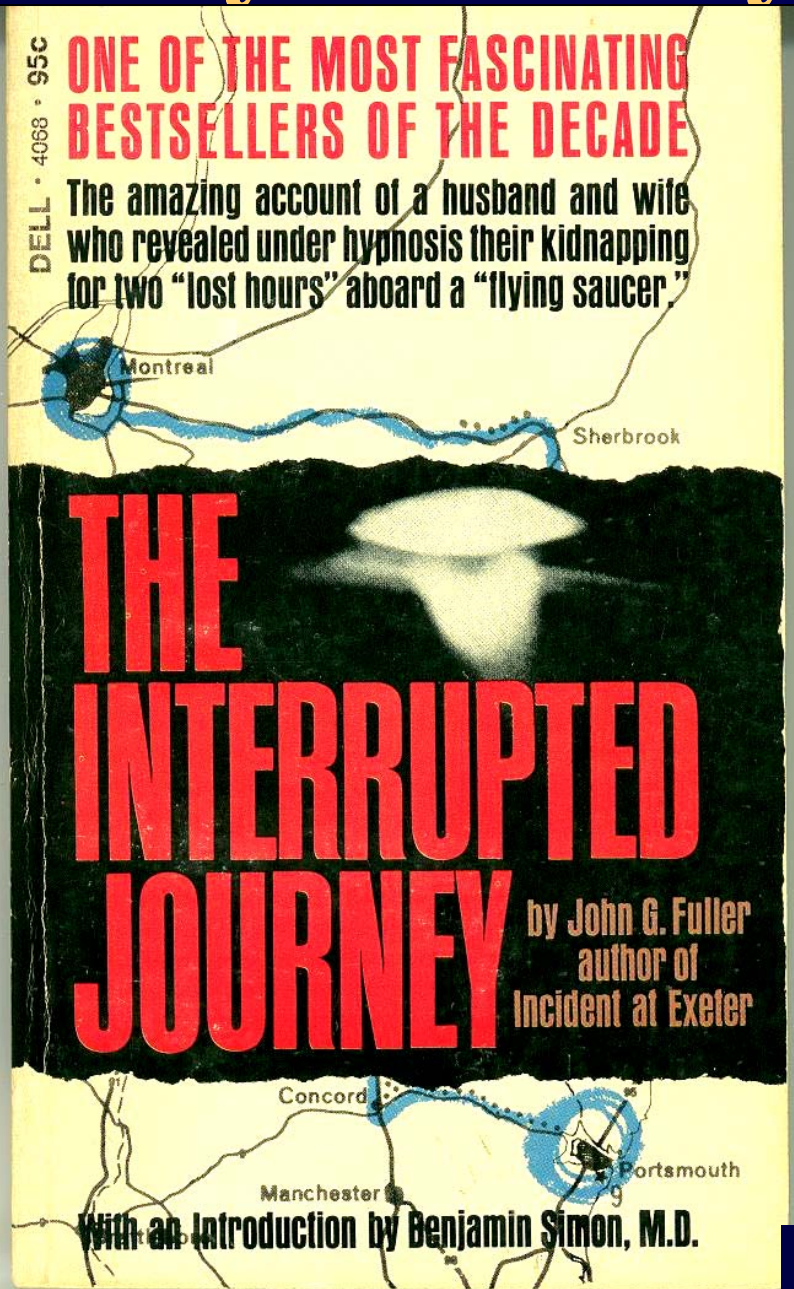

Betty's hand-drawn star map under hypnosis. Marjorie Fish 3D bead & string of 50 LY local neighborhood

GravityWarpDrive.com/Zeta_Reticuli_Incident.htm

Astronomy magazine star map verifies Betty Hill star map



Every solar-mass size star within 50 LY of earth is on Betty's star map

From *Zeta Reticuli Incident*

Historical Antigravity Research

Guidelines to Antigravity*

ROBERT L. FORWARD

Hughes Research Laboratories, Malibu, California

(Received 12 September 1962)

This paper emphasizes certain little known aspects of Einstein's general theory of relativity. Although these features are of minor theoretical importance, their understanding and use can lead to the generation and control of gravitational forces. Three distinctly different non-Newtonian gravitational forces are described. The research areas which might lead to methods for the control of gravitation are pointed out and guidelines for initial investigation into these areas are given.

INTRODUCTION

EINSTEIN'S general theory of relativity provides a number of ways to generate non-Newtonian gravitational forces. All of these forces are of the same order of magnitude as a form of anti-gravity. They were probably first described by Einstein in his paper published in 1911. Einstein's theory of relativity in 1915 was derived by Thirring and has been contained in his paper on relativity.³⁻⁵

Although non-Newtonian, these forces were little known to the theorists of the time. It was for this reason that a detailed discussion of their effects would be of interest.

The equations of the general theory of relativity predict the usual force behavior of a stationary test body, but they also predict that a mass can create a field similar to the gravitational field, although the forces, although they result in a stationary field, they result in a stationary field.

field relations similar to the Maxwell relations. Thus one can use intuitive pictures from electromagnetic theory to design theoretical models. Whether the effects predicted by the linearized theory, have to be compared with the usual Newtonian theory, these unusual forces are independent of the forces are, in the usual New-

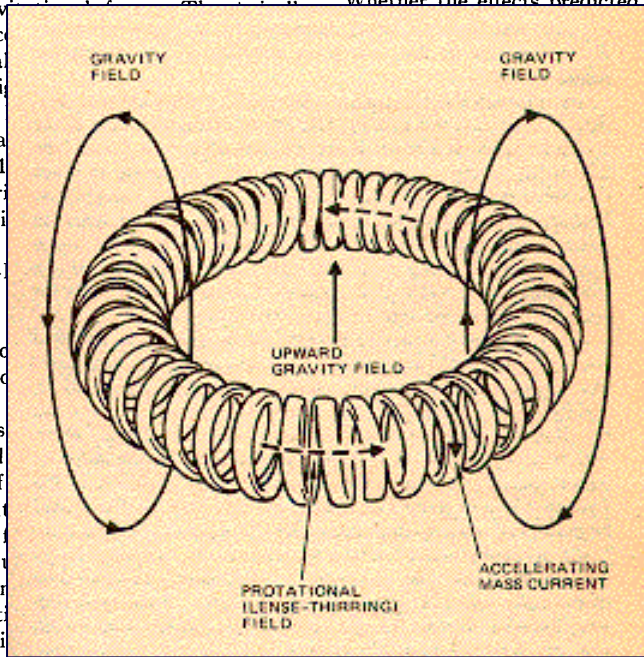

GRAVITATIONAL FORCES ON STATIONARY BODIES

From the theory of relativity it can be shown that a stationary body contains terms of the order of the body. One can rigorously investigate the behavior of a body in the x - y plane, on a stationary field approximately

$$z = - (MG\omega^2/c^2R)z, \quad (1)$$

* This paper was submitted as an essay to the Gravity Research Foundation in 1962 and received the Second Award.

¹ A. J. see also publication
² H. ...
³ C. I.

Published in 1962

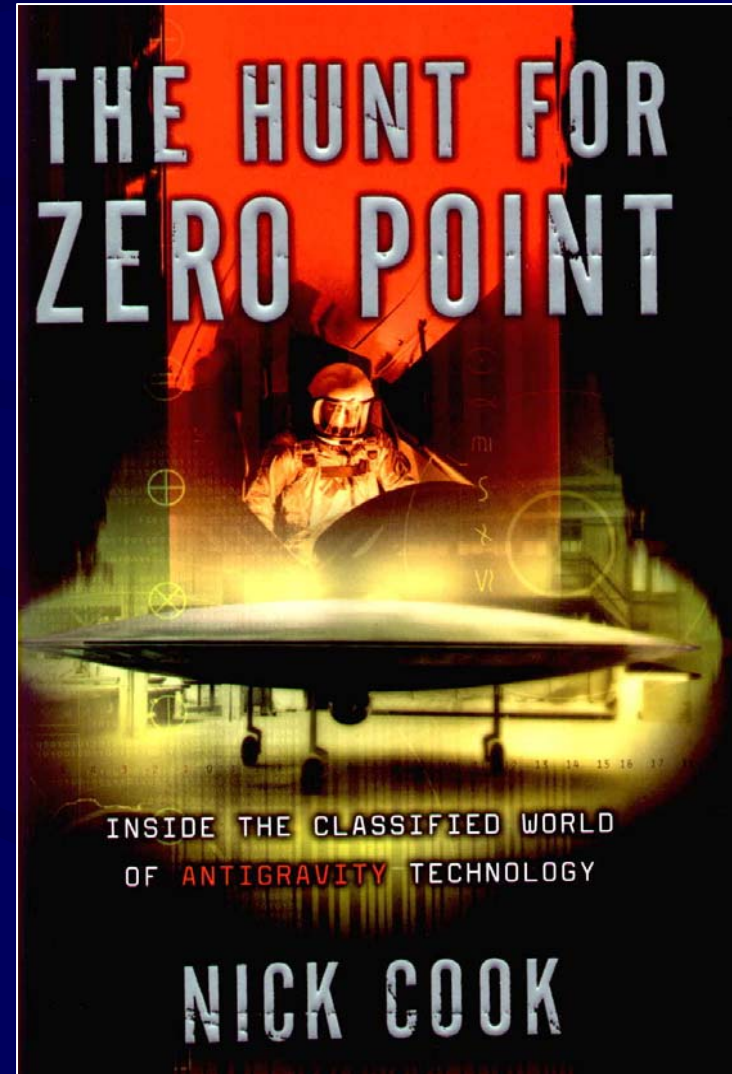

Published in 2001

Random House Publishers

PAUL R. HILL UNCONVENTIONAL FLYING OBJECTS

a
scientific
analysis

"Paul Hill has done a masterful job ferreting out the basic science and technology behind the elusive UFO characteristics.... Perhaps this book will help bring solid consideration for making all that is known about extraterrestrial craft publicly available."

—Edgar Mitchell, Sc.D., Apollo 14 Astronaut

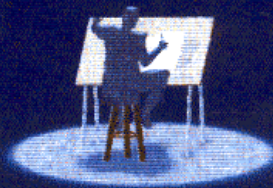

Former NASA scientist, learned from eye witnesses, and Tremonton 1956 film of a UFO. Calculated inertia-free turns and force field propulsion.

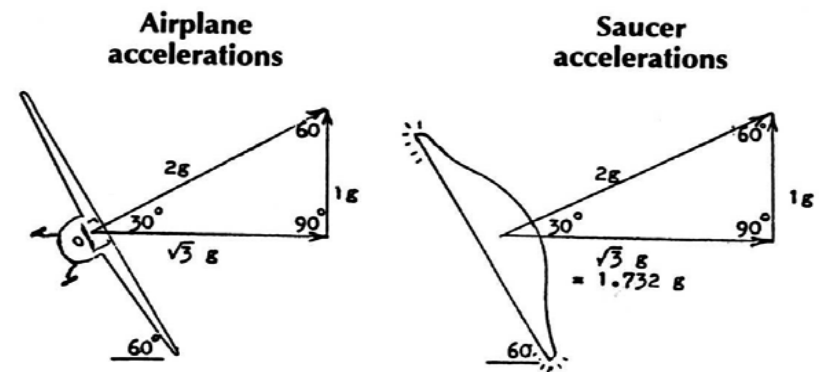

Figure XI-5. Sixty-degree banking turns.

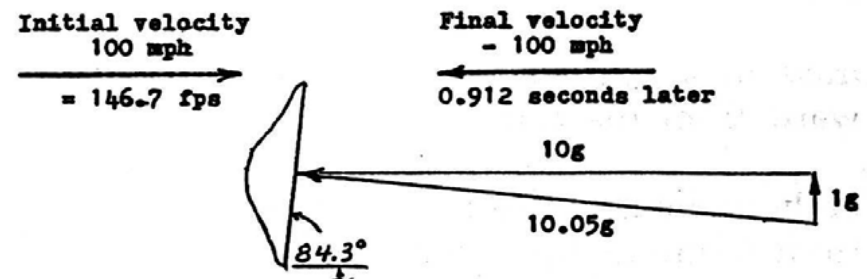

Figure XI-4. Saucer Making 10 g Reversal.

The Most Authentic UFO Footage in My Collection



Principles of Field Propulsion

**Secondary
Gravitational
Force Field:
Nuclear
Strong Force
extended**

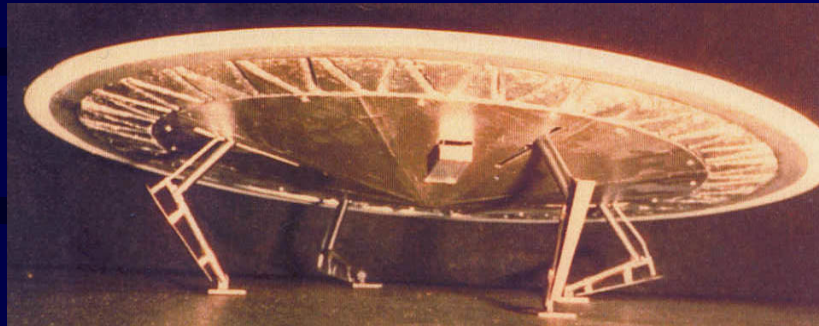

John R. R. Searl
Electrogravitics



Electrokinetics
T. T. Brown

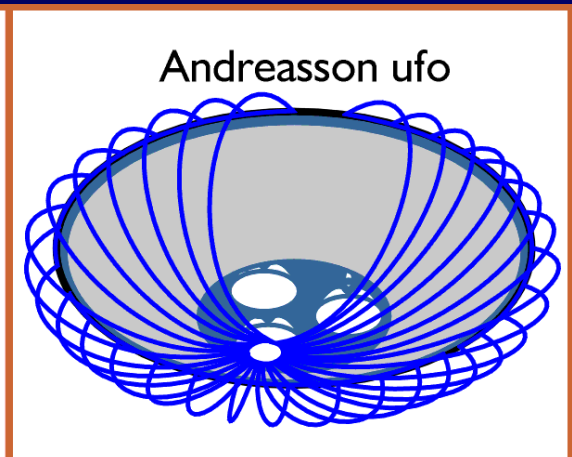
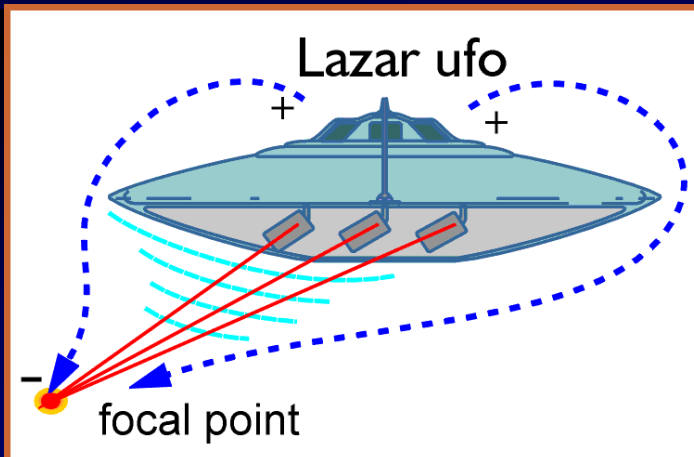

Hydrodynamic Model of Vehicle Interactions with ZPF

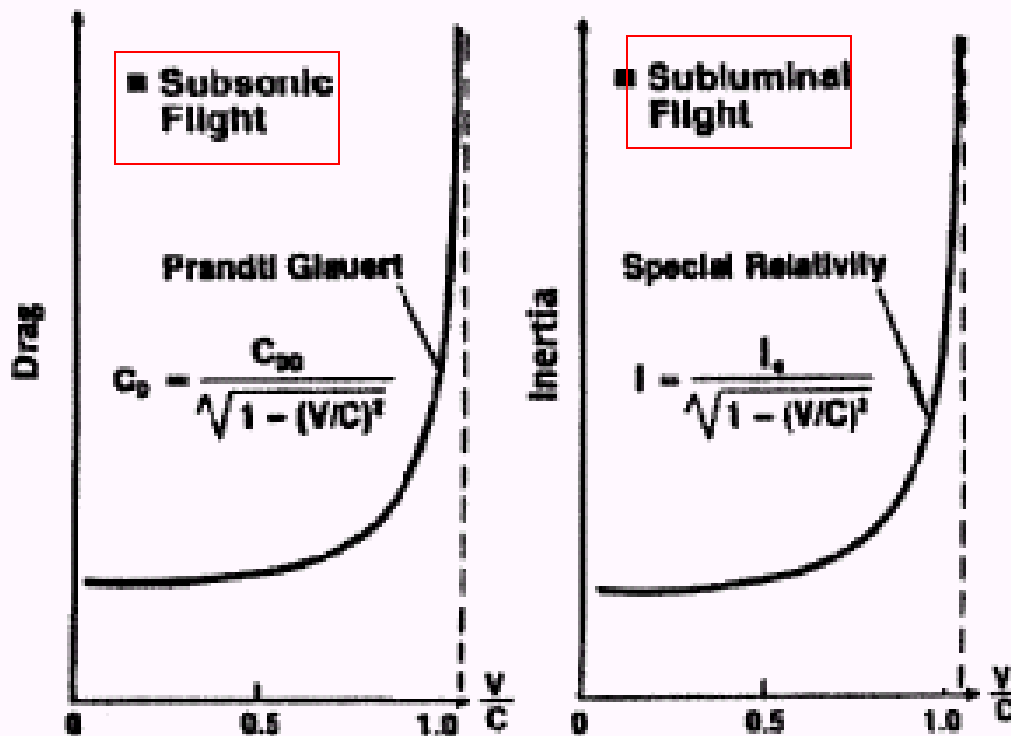

- Resistance vs. speed for sound and for light is same
- speed of light $c = (\mu_0 \epsilon_0)^{-1/2}$
- sound speed $c = (qR\gamma T)^{1/2}$
- Aerodynamic viscous drag is compared to the Lorentz force exerted by the ZPF

- $\mu_0 \epsilon_0$ and Einstein-Hopf drag $F = -R v$ can be reduced by nonabelian electromagnetic fields with a toroid

Fronig, 38th JPC, AIAA-2002-3925

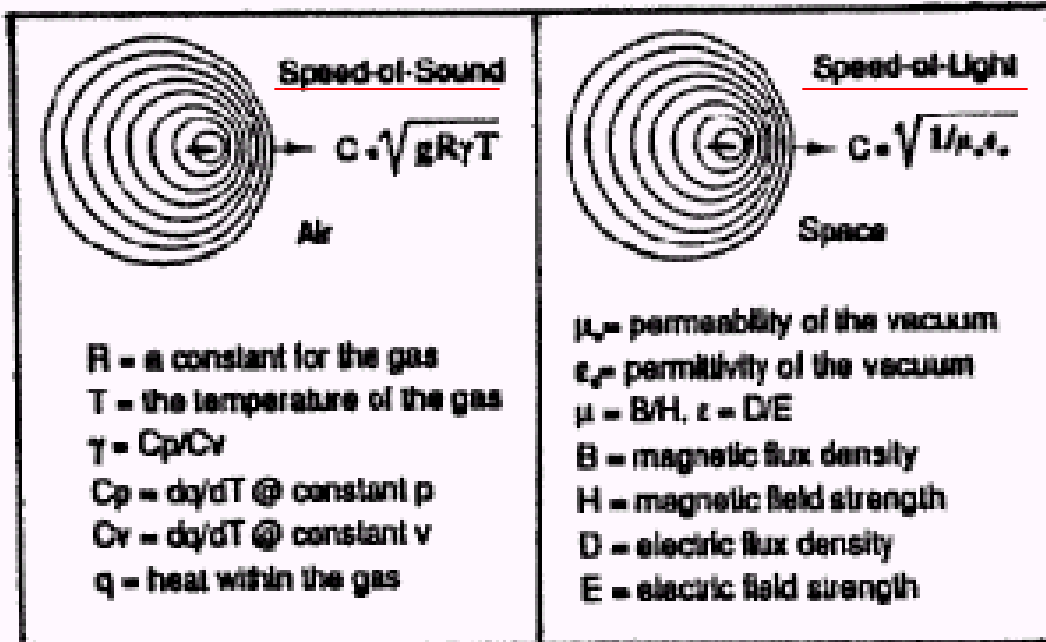

Flight Resistance Increase with Speed

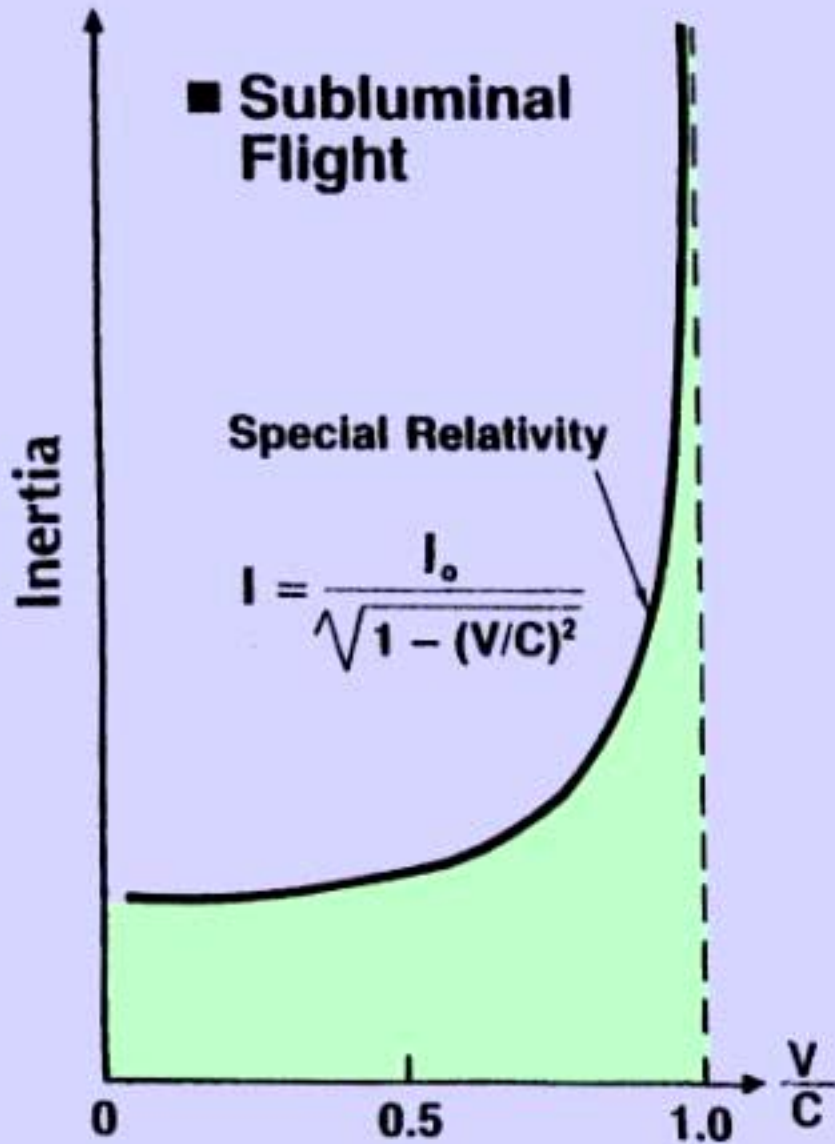
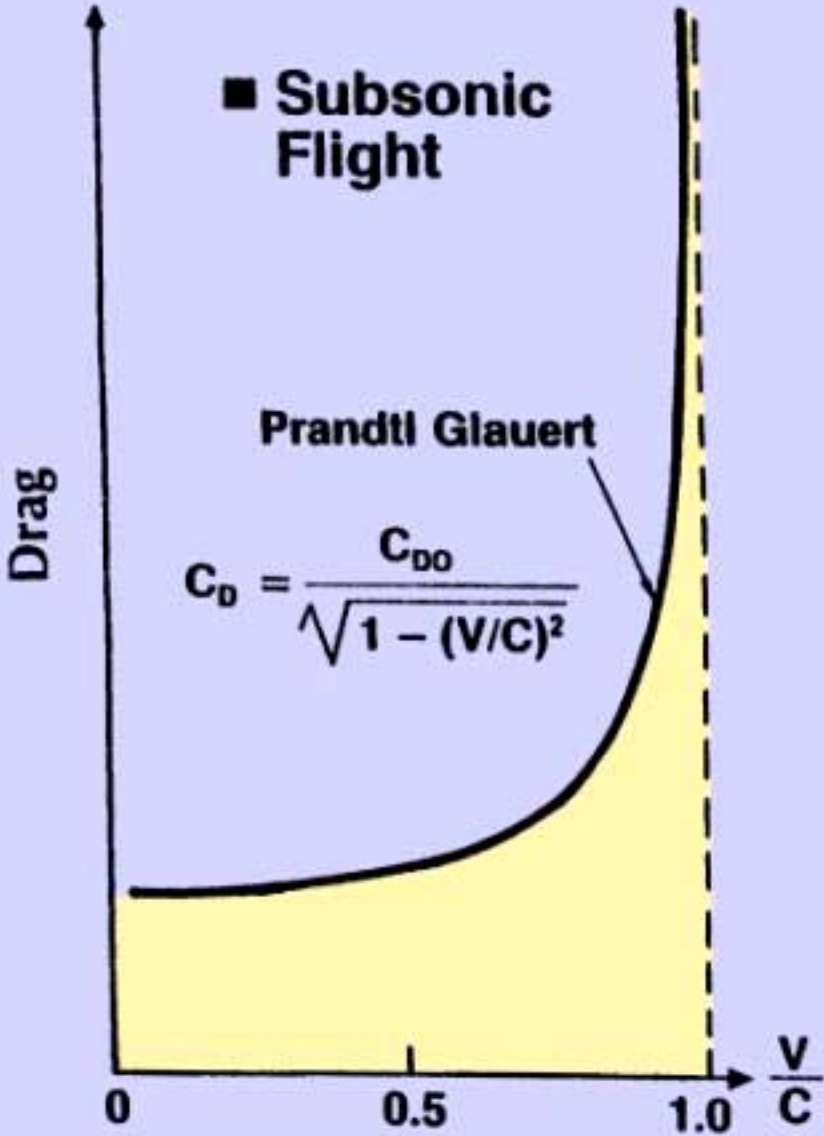

Speeds of Acoustic and Electromagnetic Wave Fronts in Air and Space

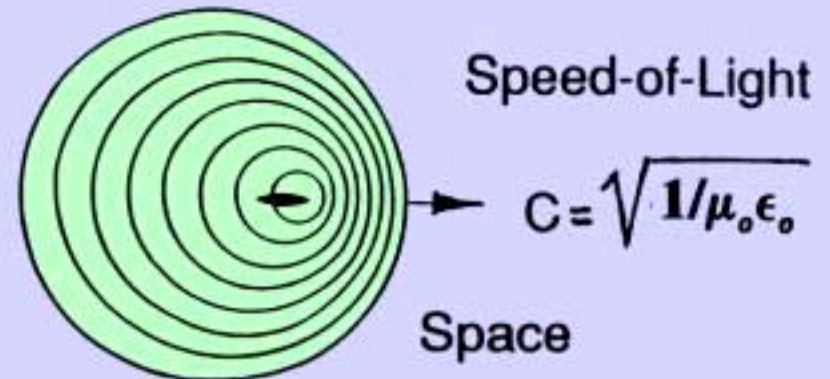
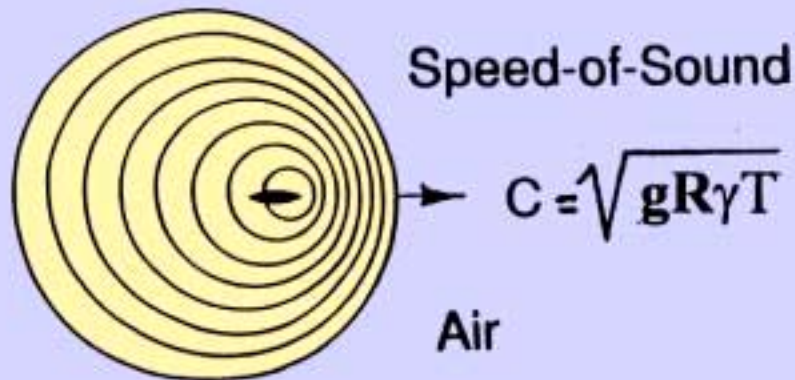

R = a constant for the gas
 T = the temperature of the gas
 $\gamma = C_p/C_v$
 $C_p = dq/dT$ @ constant p
 $C_v = dq/dT$ @ constant v
 q = heat within the gas

μ_0 = permeability of the vacuum
 ϵ_0 = permittivity of the vacuum
 $\mu = B/H$, $\epsilon = D/E$
 B = magnetic flux density
 H = magnetic field strength
 D = electric flux density
 E = electric field strength

Superluminal Saucer

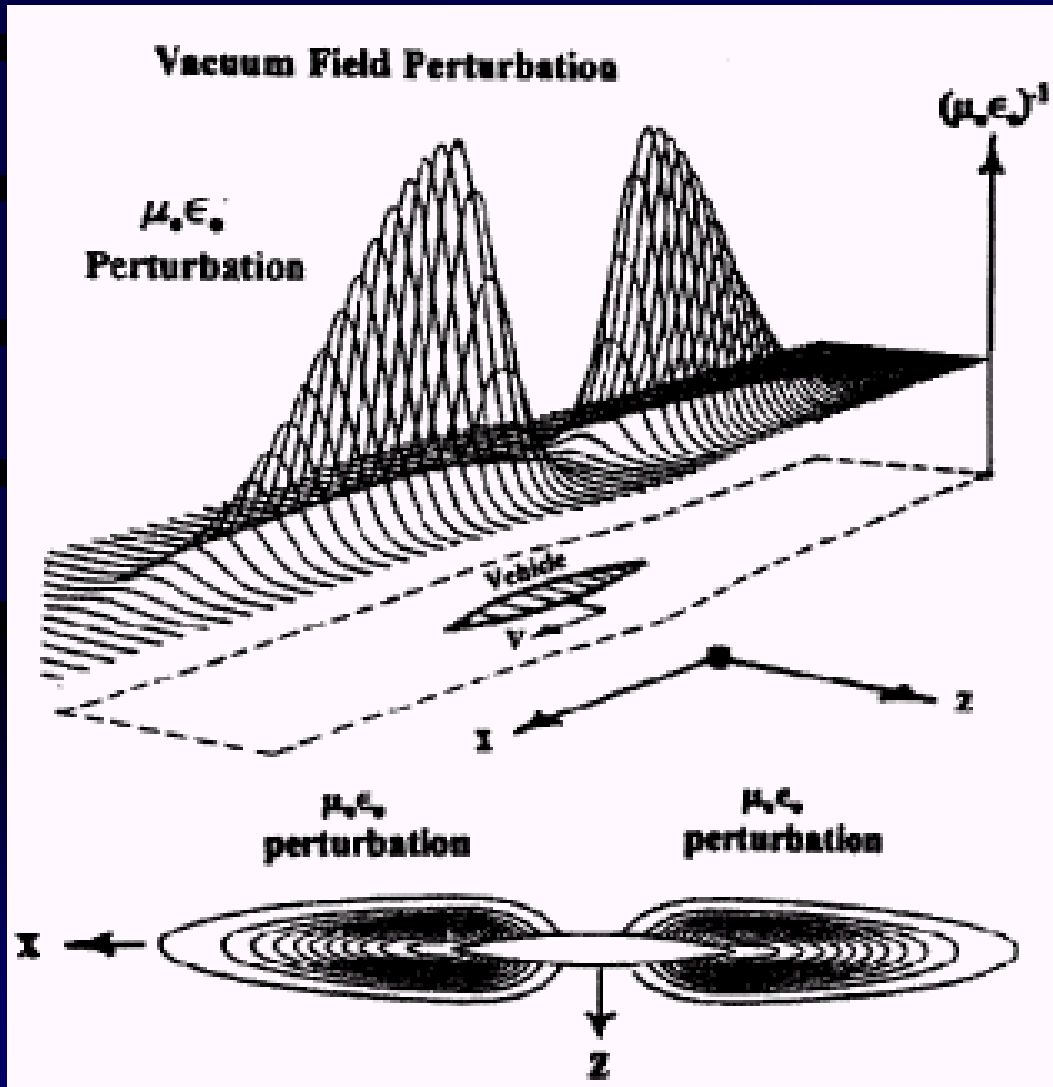

- Fronig solved Euler eqs of fluid dynamics with vacuum perturbed by toroidal EM field
- ZPF loses its drag when $T = 0^\circ \text{ K}$ (absolute zero)
- Only directional accelerating recoil left
- Transfers energy from ZPF to vehicle
- **H. David Froning**
- www.quantumfields.com

Spacetime-Warping and Vacuum-Polarizing Ship

thin repulsive field interaction region formed
along outer skin of space-warping ship



perturbed EM permittivity and permeability
within interior of vacuum-polarization ship

← Acceleration with respect to Earth

$M=.99$ $\gamma=\text{const}$

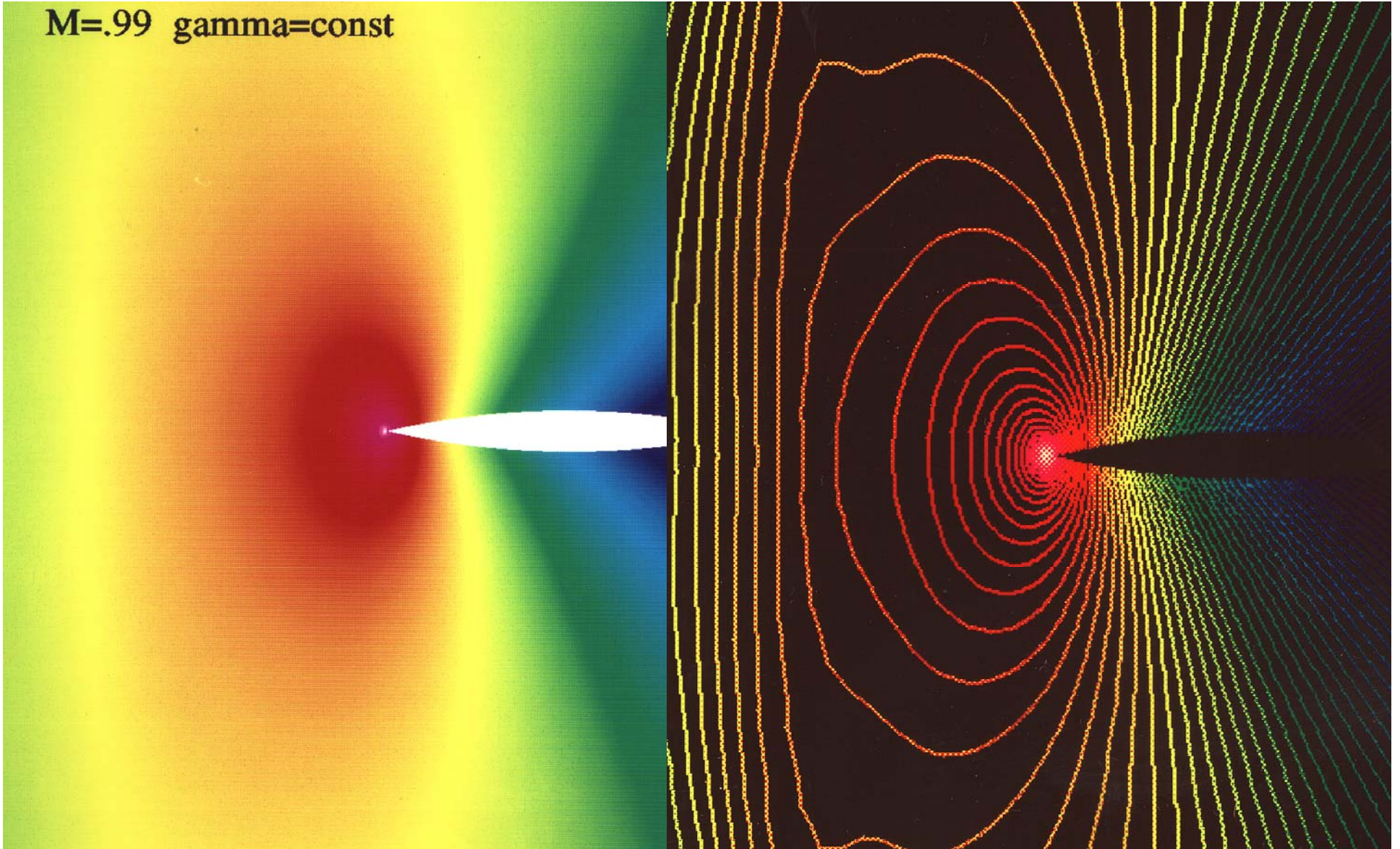

Thermal Radiation Pressures
in Air at Mach 0.99

Vacuum Zero-Point Radiation
Pressures in Space at $0.99c$

Positive Thermal Radiation Pressures Exerted on a High-Speed Vehicle by Atmospheric Air

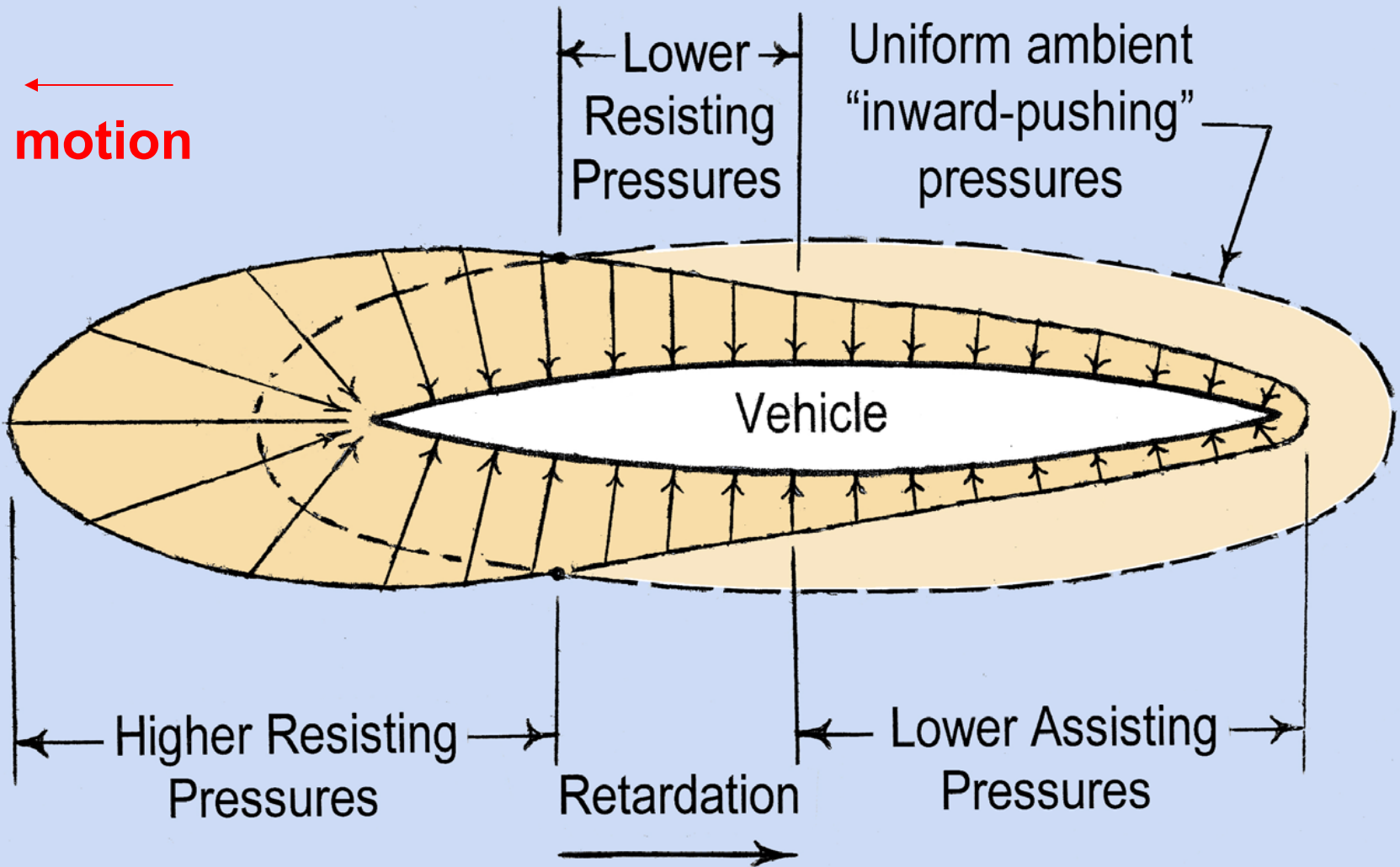

Negative Zero-Point Vacuum Radiation Pressures Exerted on a High-Speed Vehicle

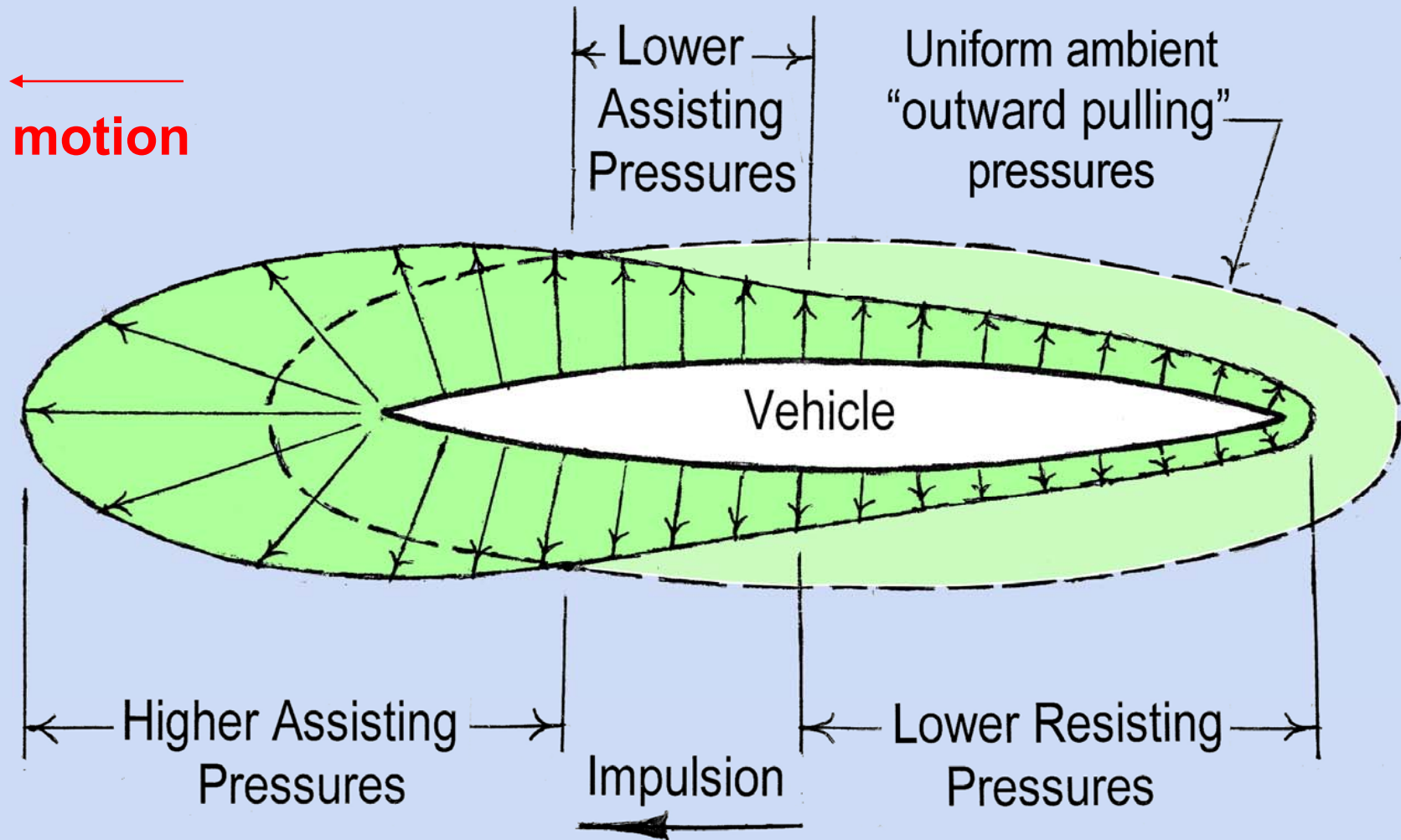

Speed = c

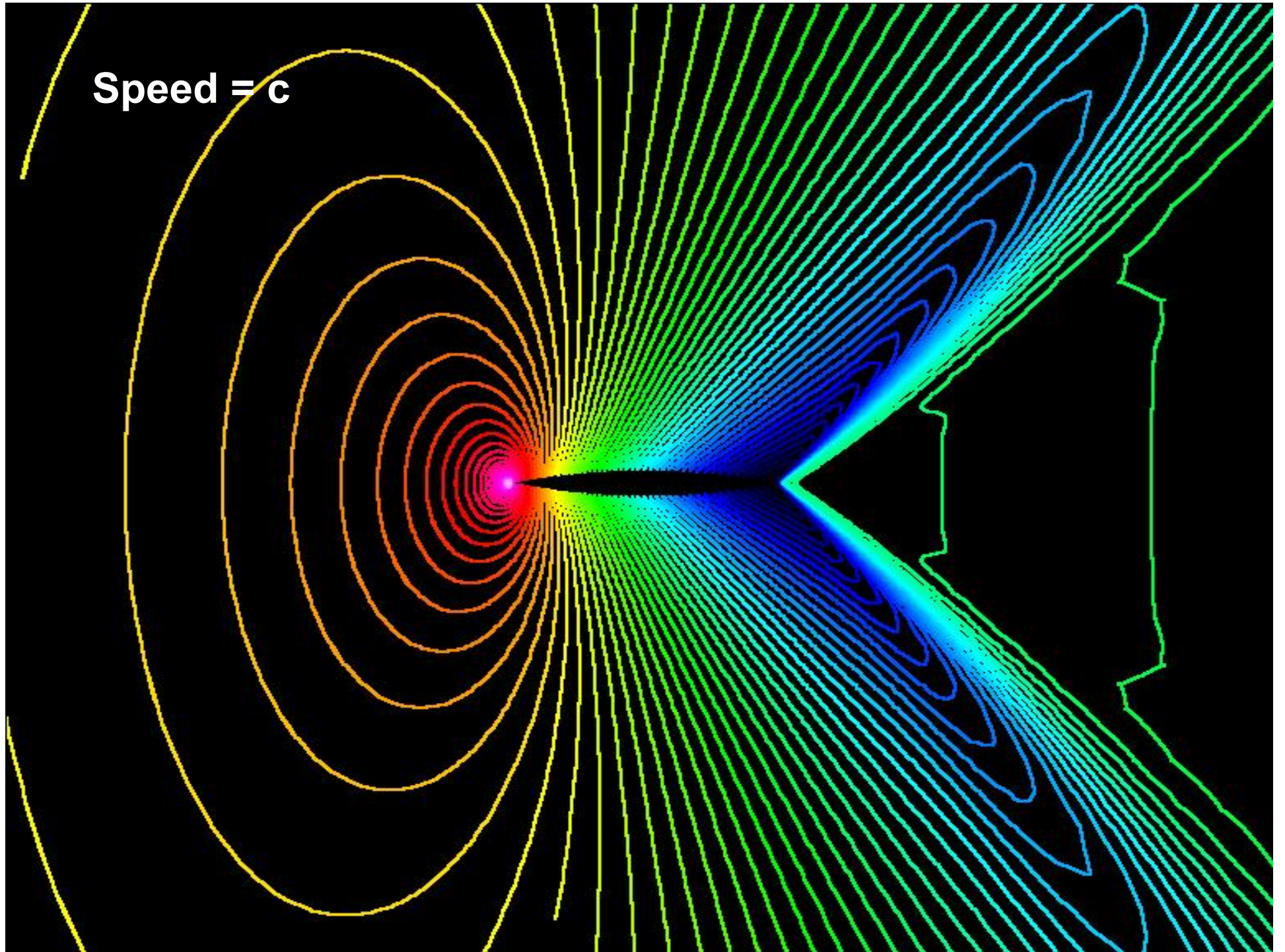

Speed = $2c$

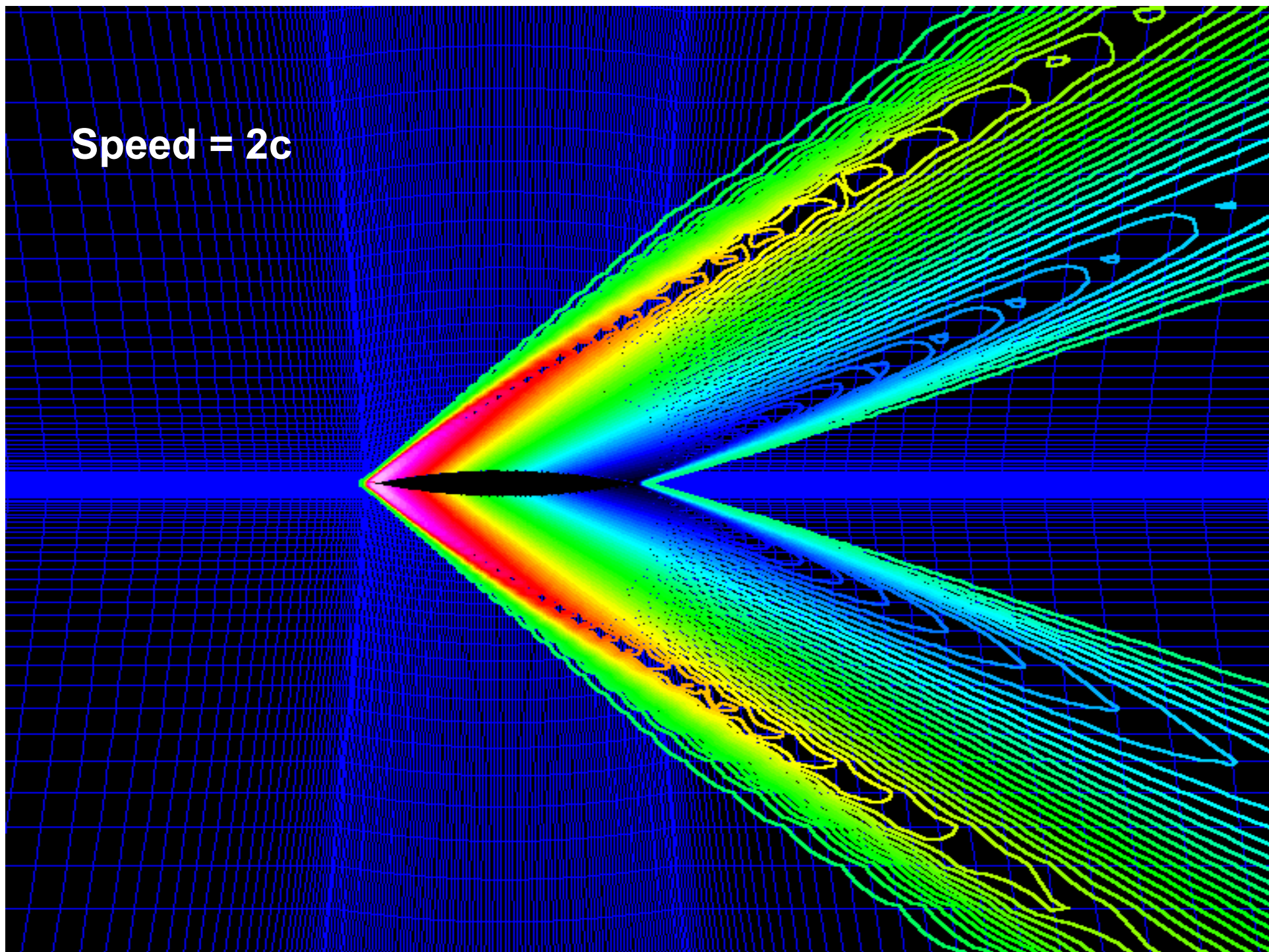

Speed = $3c$

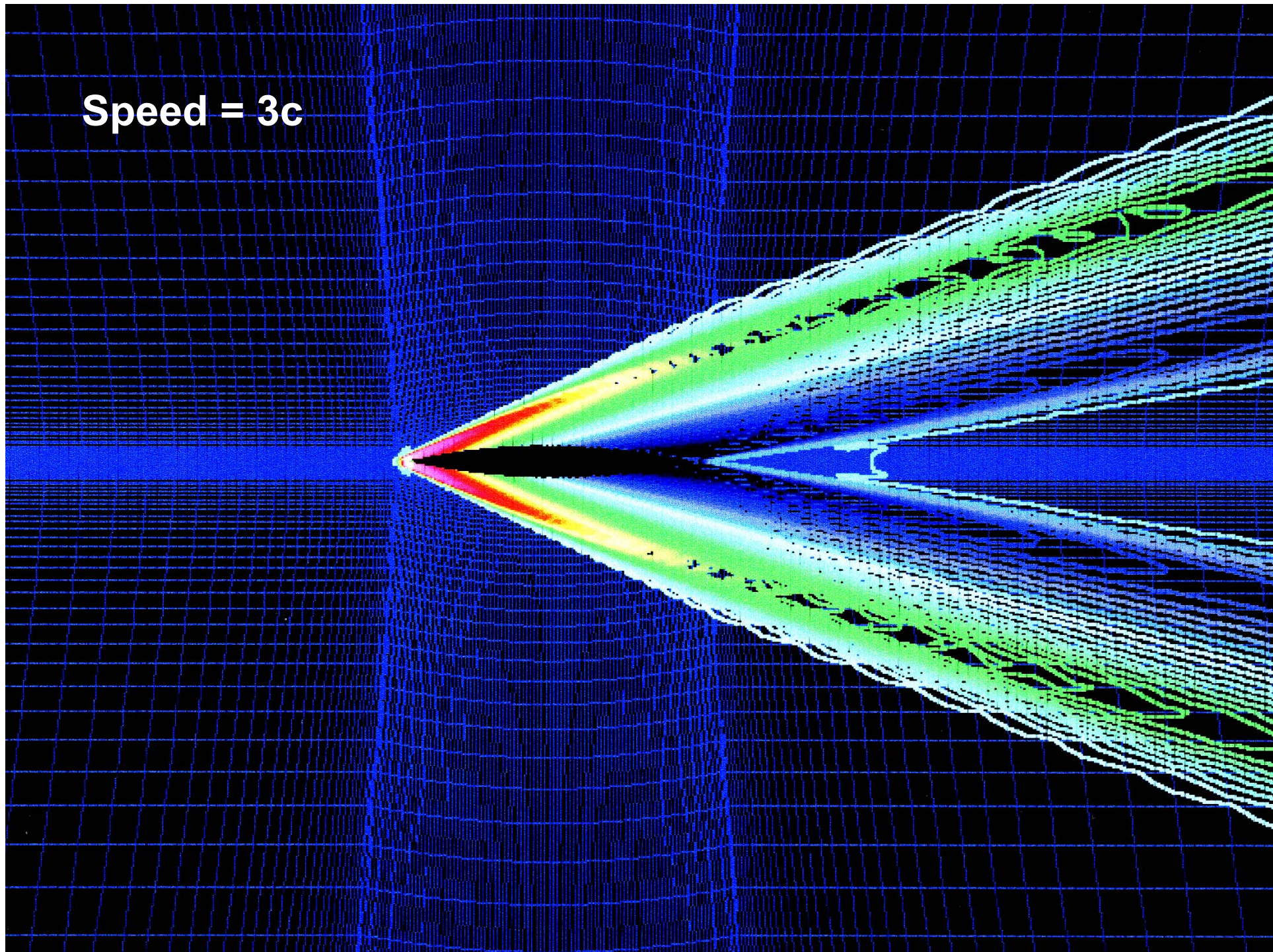

Belgian Congo UFO Drawing

1952 sighting – gov't document – *Disclosure* by Steven Greer

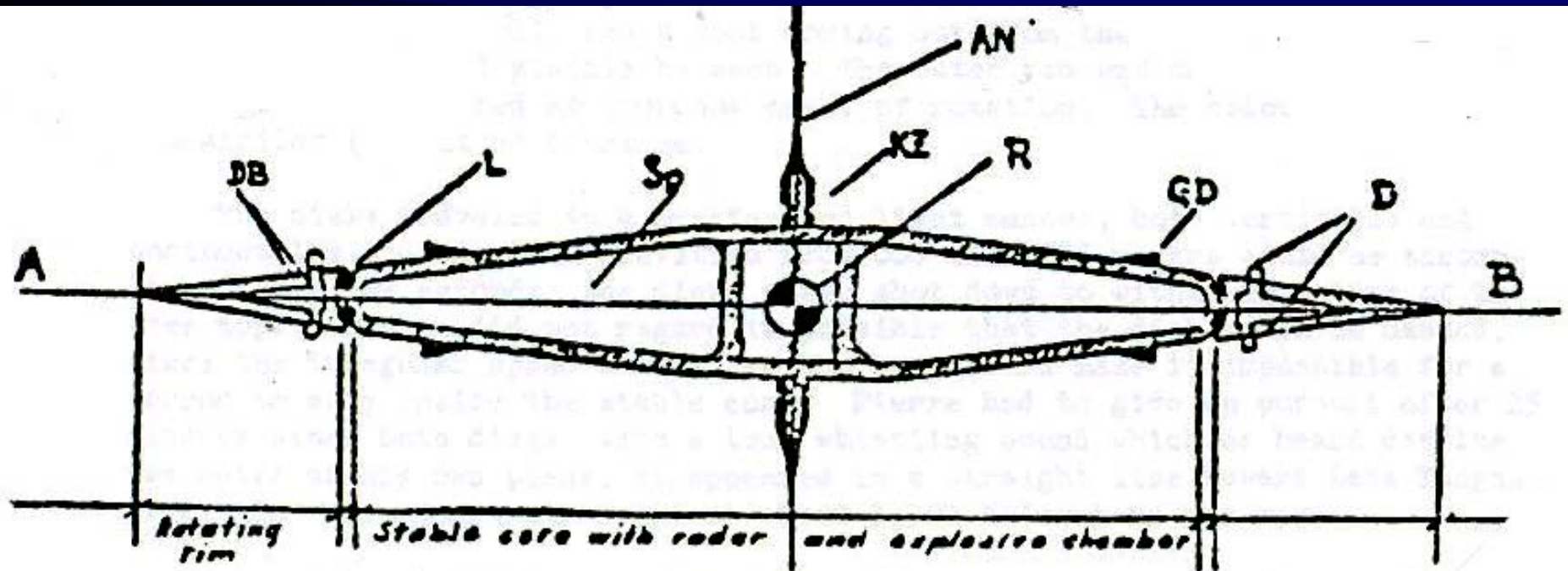

UFOs Over Washington DC



FOX News 2008

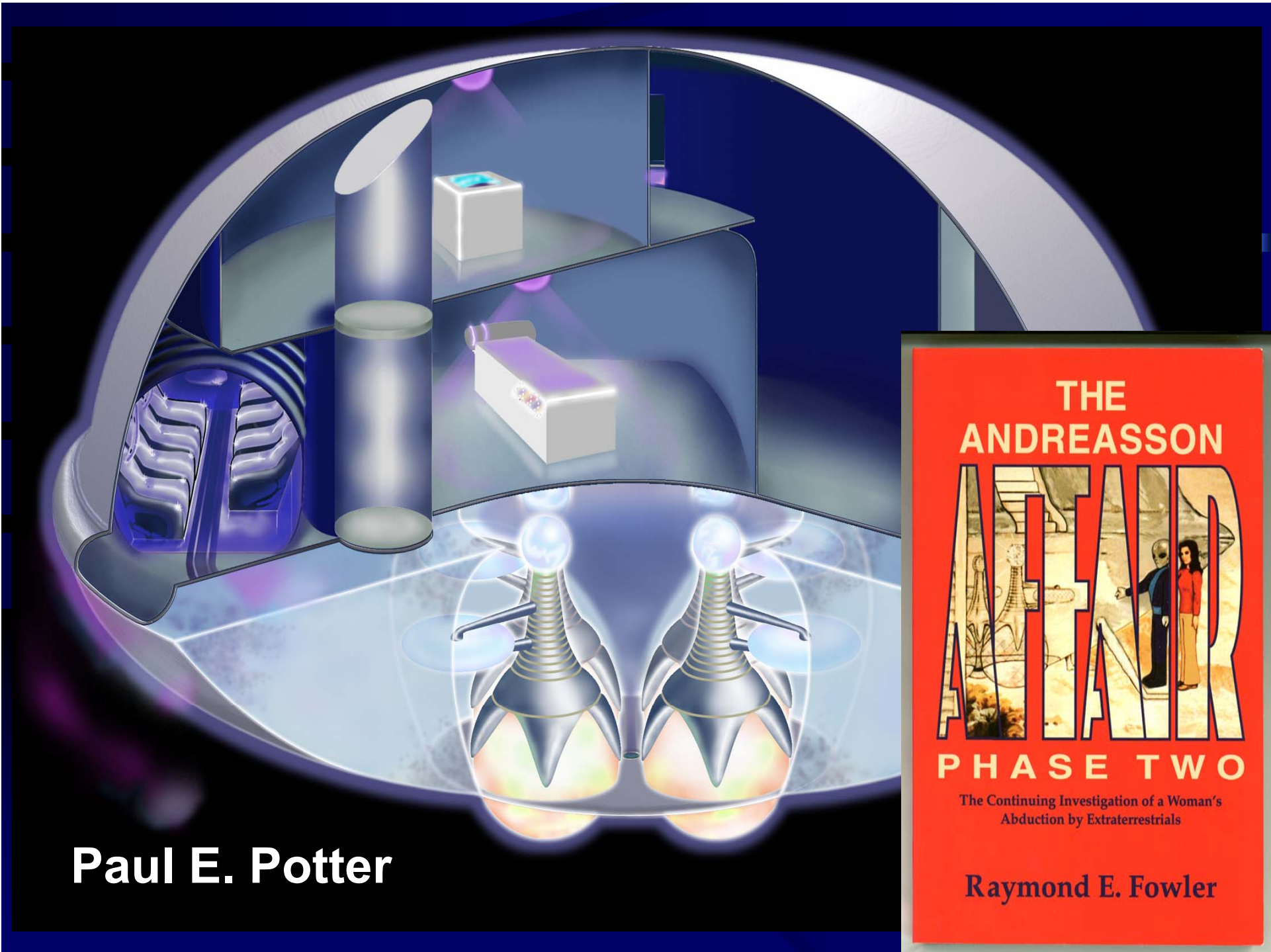

Paul E. Potter

**THE
ANDREASSON**



PHASE TWO

The Continuing Investigation of a Woman's
Abduction by Extraterrestrials

Raymond E. Fowler

these wheels move in the hollow of the toroid where there is no electric charge (hollow conductor) - this is why they are supported by the insulated section of the sphere structures. Moving them through the magnetic field lines may induce movement of charges

Fig. 3

any suspensoid body of higher conductivity or dielectric constant than the medium is caused to move toward the region of highest field intensity (by dielectrophoresis) J. App. Phys. 22:871 (Aug 1951)

crystal sphere becomes highly charged

insulation

suspensoids

a liquid flow builds up charge within its layers (viscous fluid when propelled forms into laminar layers, these layers rotate at different speeds, thereby creating friction and, by triboelectric charging - electric charge) - even more so when the liquid holds insulated suspensoids of conducting materials

negative charge streams over to accumulate on lower spheres

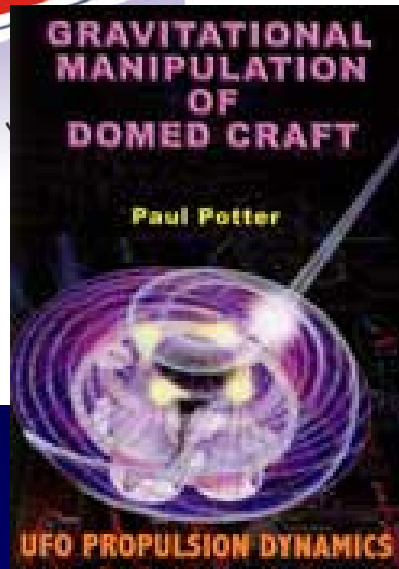
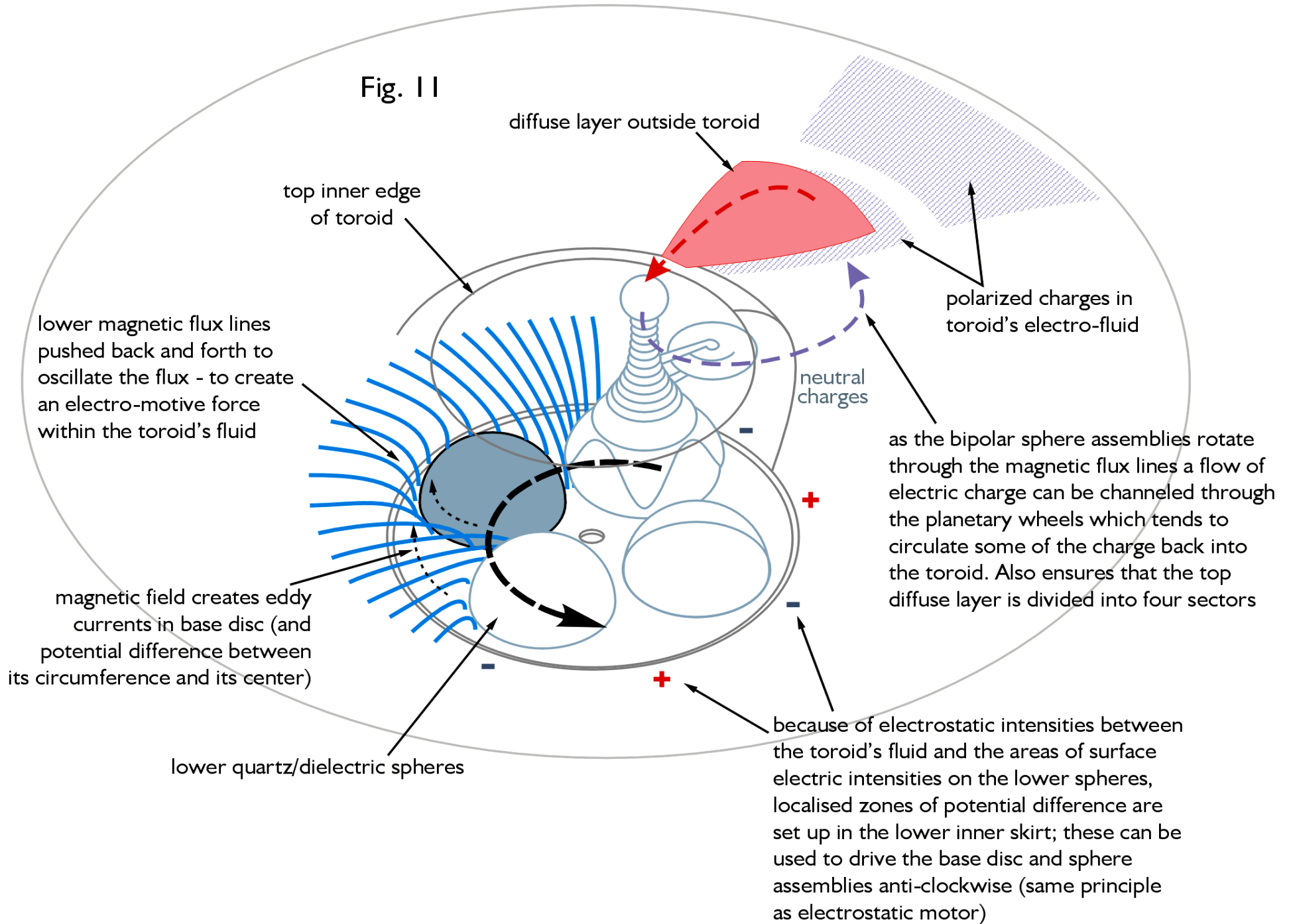
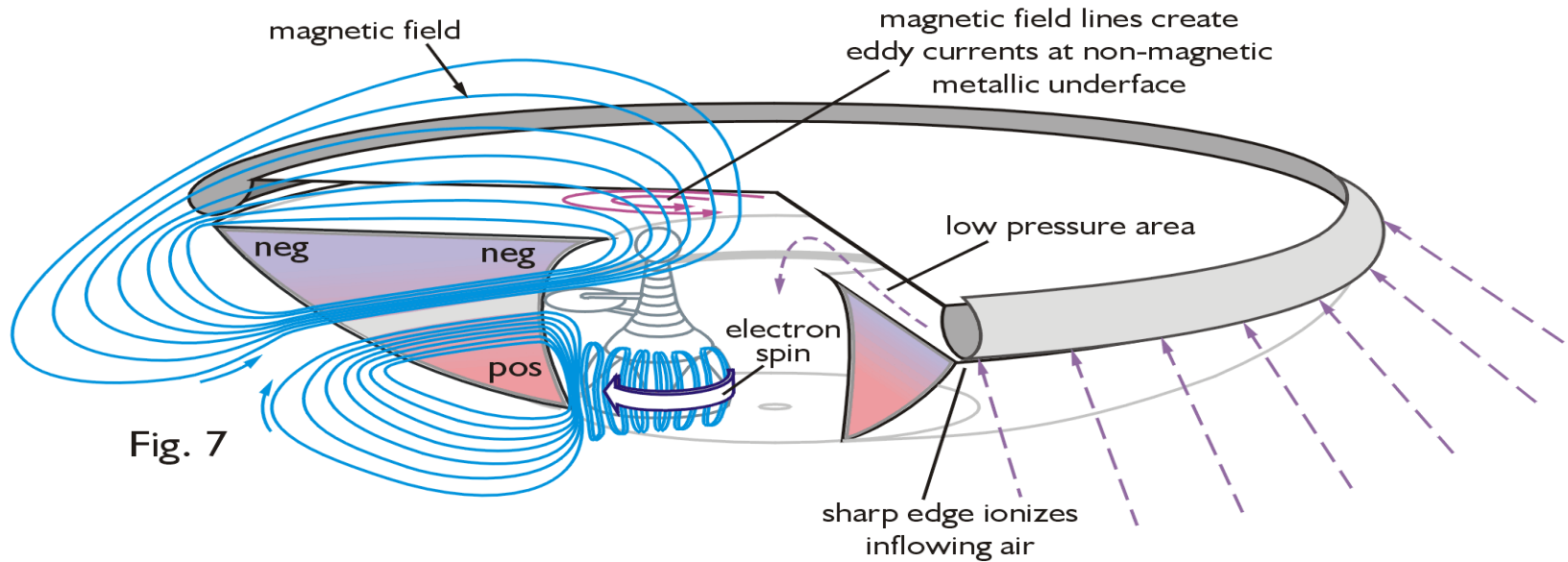
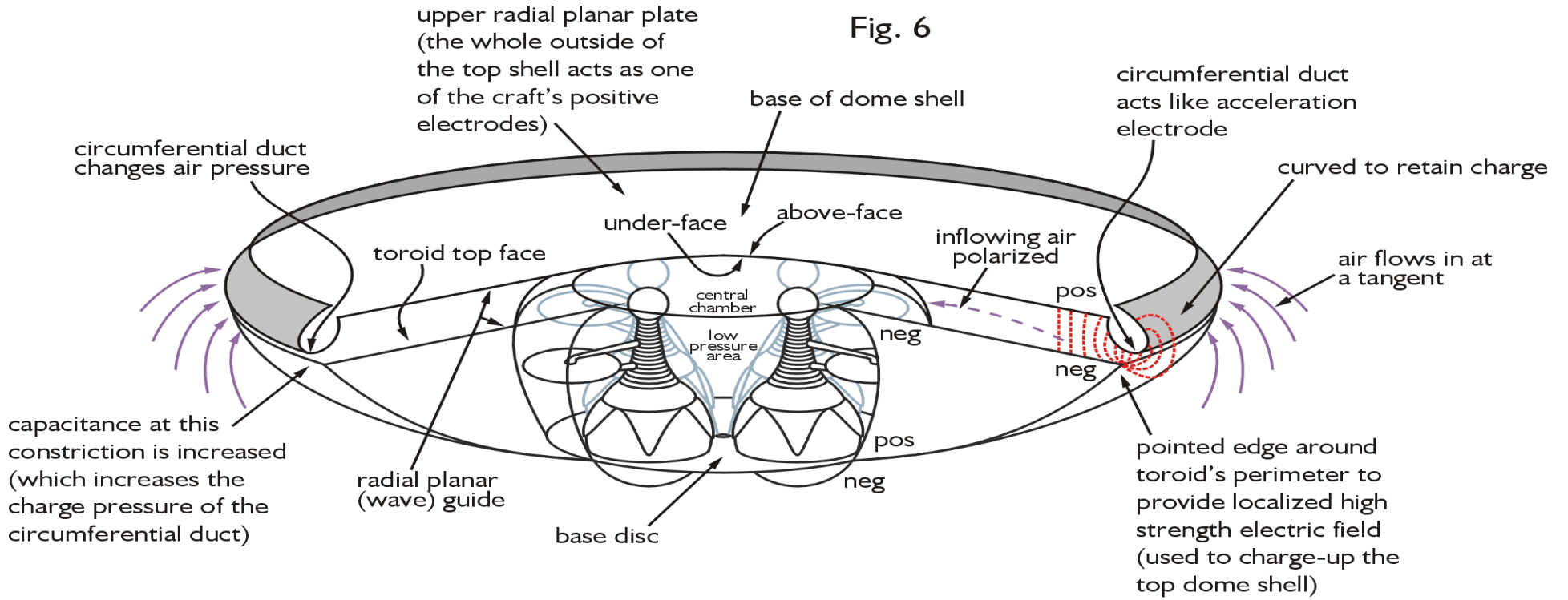

Fig. 11





toroid containing electrolytic fluid

Fig. 16

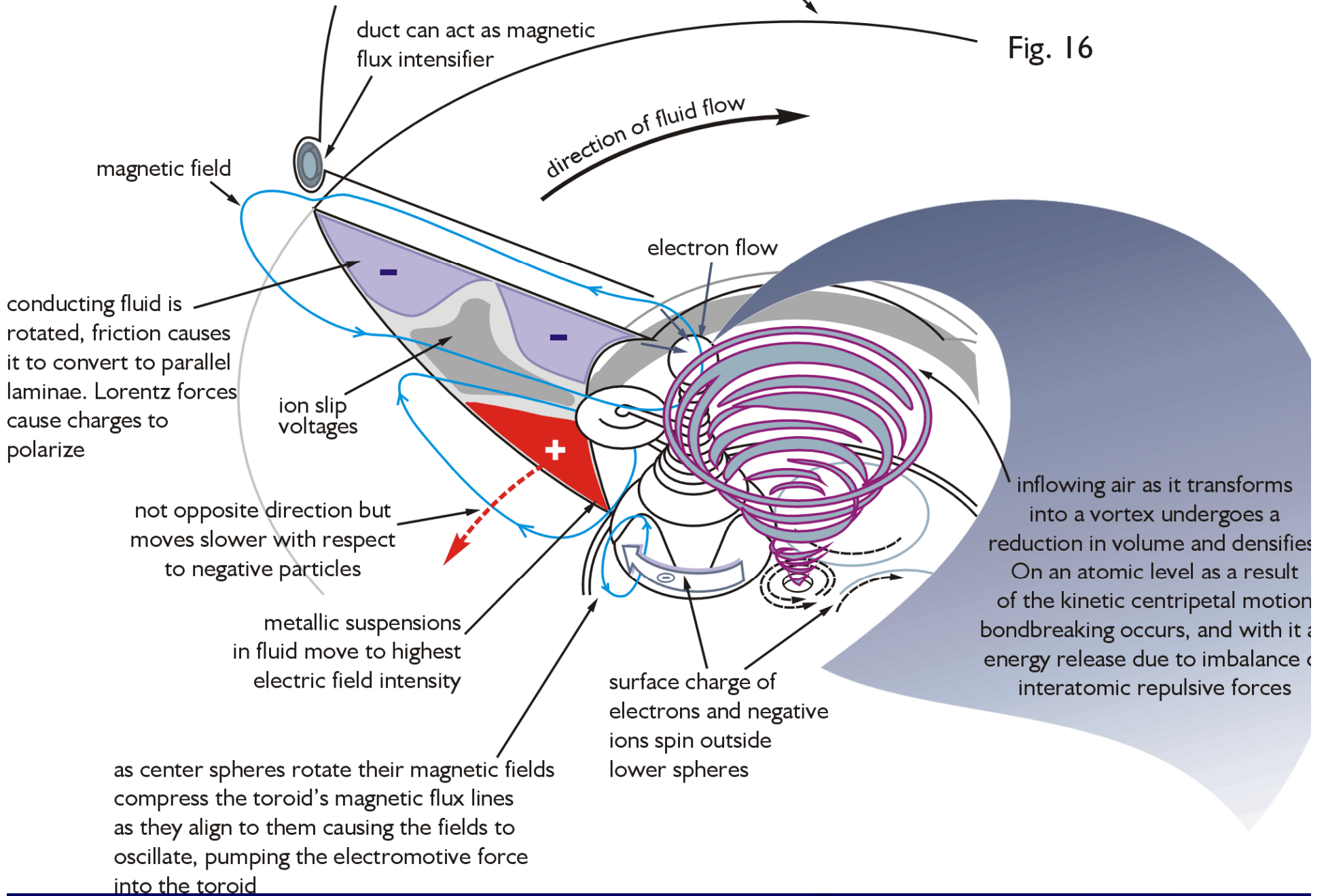

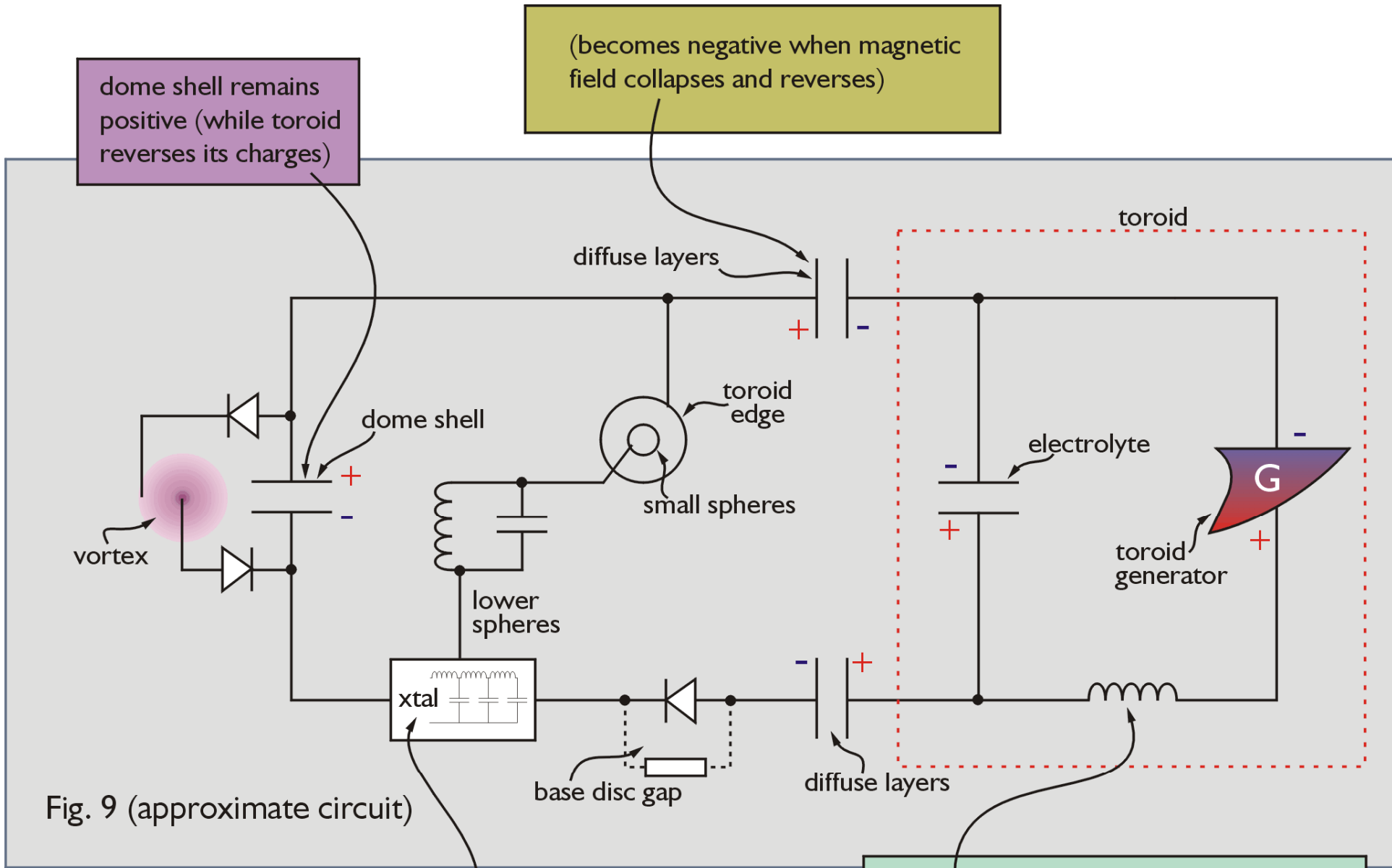

dome shell remains positive (while toroid reverses its charges)

(becomes negative when magnetic field collapses and reverses)

Fig. 9 (approximate circuit)

the dielectric (by dielectric absorption) will accumulate electric charge when oscillated

the combination of particle polarization, magnetic field, and the liquid's motion will provide an inductance in the toroid

Grangemouth

- **Electrogravitics propulsion**
- **120° conductor placement**

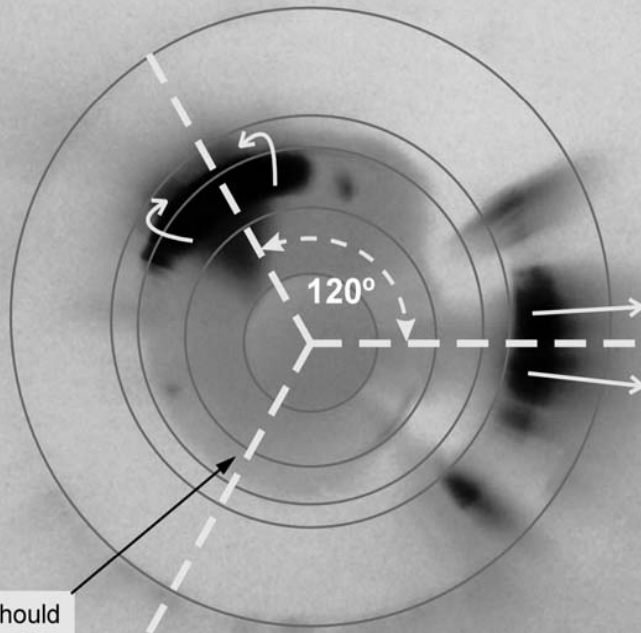

third conductor should be in this area

Grangemouth ufo

Analyzing UFO
energy technology

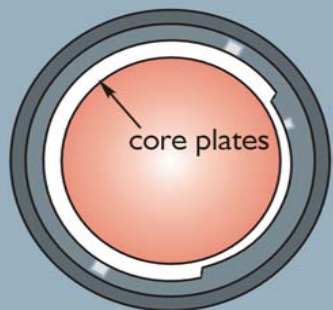
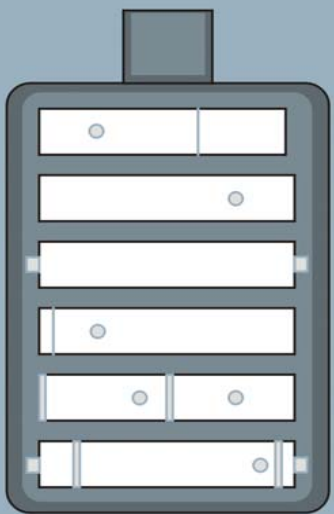

Lazar

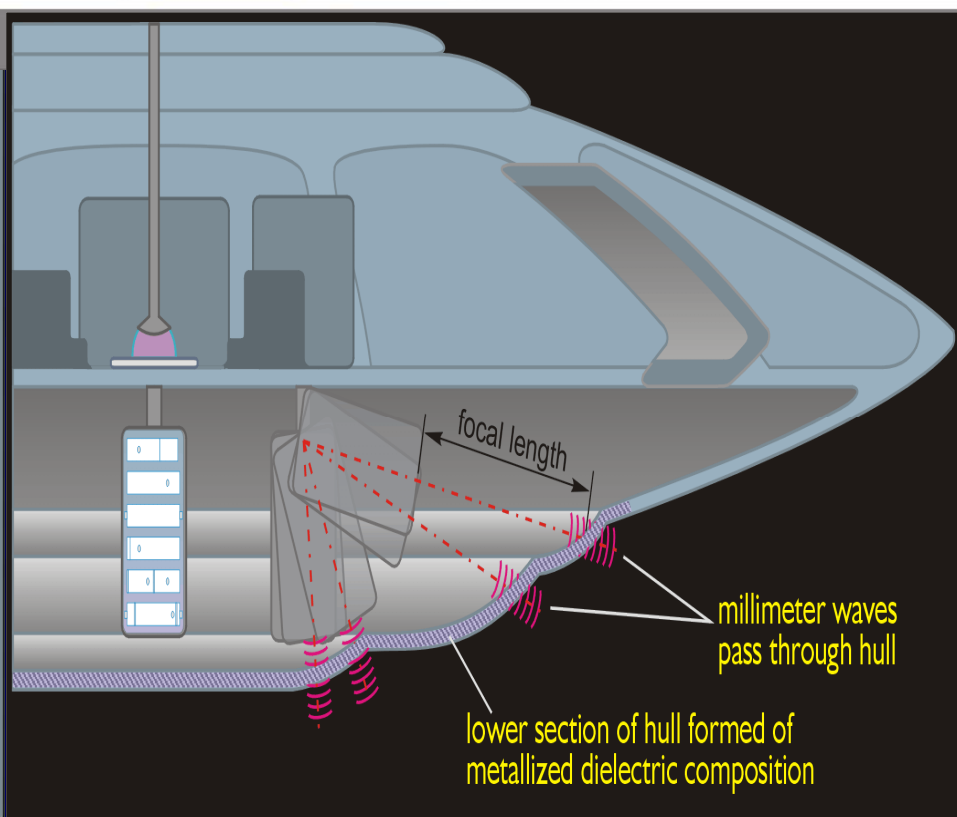
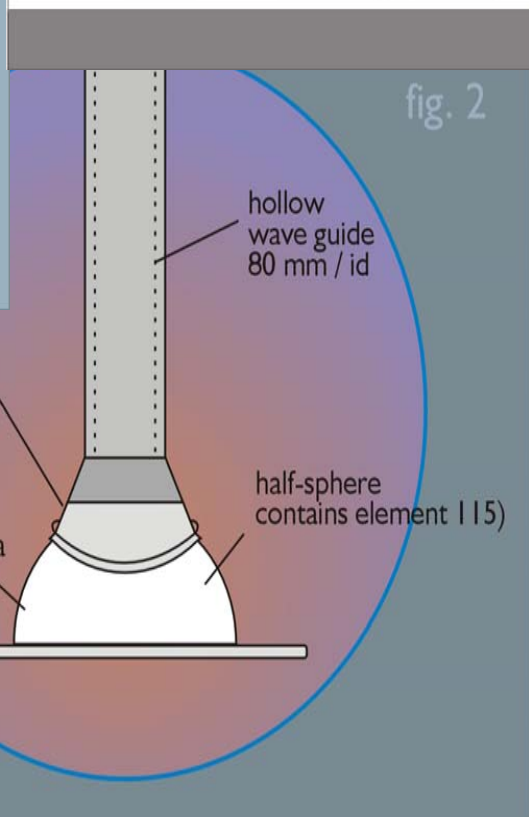
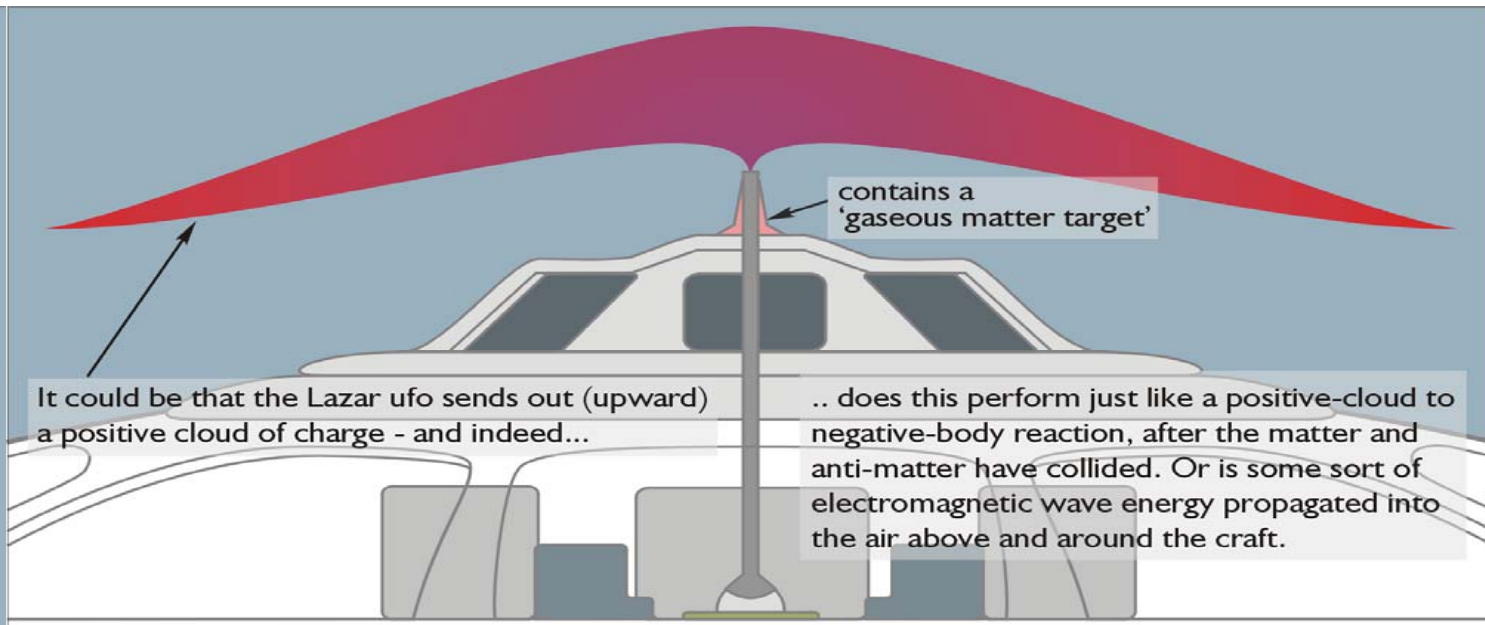

Bob Lazar's "Sport Model"

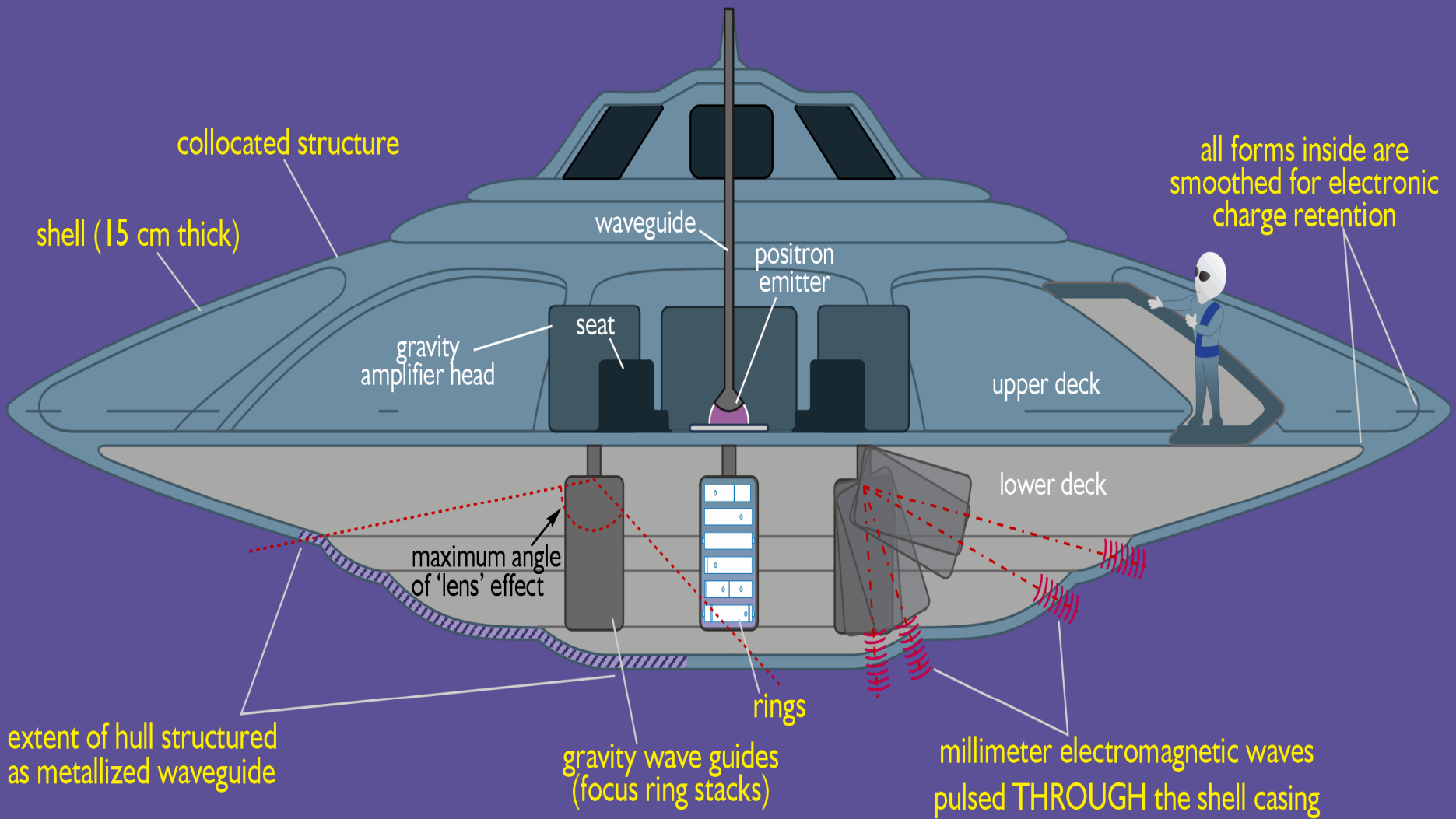

Black Projects Have Field Propulsion

Dr. Bruce
Cornet,
geologist led
group of eye
witnesses

Photo credit:
W. Marc
Whitford



- Pine Bush near Stewart AFB
- Delta-shaped aircraft 
- Two mobile white headlights
- Steady red, green lights and blinking yellow lights on tips of craft
- No visible contrail
- Abrupt change of direction
- Ability to hover motionless
- Inverse Doppler effect
- Audible but low engine noise

Inertia as a zero-point-field Lorentz force

Bernhard Haisch

*Lockheed Palo Alto Research Laboratory, Division 91-30, Building 252, 3251 Hanover Street, Palo Alto, California 94304
and Max-Planck-Institut für Extraterrestrische Physik, D-85740 Garching, Germany*

Alfonso Rueda

Department of Electrical Engineering, California State University, Long Beach, California 90840

H. E. Puthoff

Institute for Advanced Studies at Austin, 4030 Braker Lane West, Suite 300, Austin, Texas 78759
(Received 8 February 1993)

“The ZPF will exert a magnetic Lorentz force...”

honored classical technique), it is shown that a heretofore uninvestigated (magnetic component of the Lorentz force) arises in any accelerated reference frame from the interaction through asymptotically

**Resistance to acceleration results from
Davies-Unruh effect (acceleration-caused flux
of radiation scattering)**

$$\mathbf{F} = (e/c) \mathbf{v}(t) \times \mathbf{B}_{\text{ZP}}(0,t) = - [\Gamma \hbar \omega^2 / 2\pi c^2] \mathbf{a}$$

BENEFITS OF INERTIAL SHIELDING

Force = (inertial mass) • acceleration

A subject worthy
of research and
testing

$$F = ma$$

depends only on
inertial mass, not
gravitational
mass

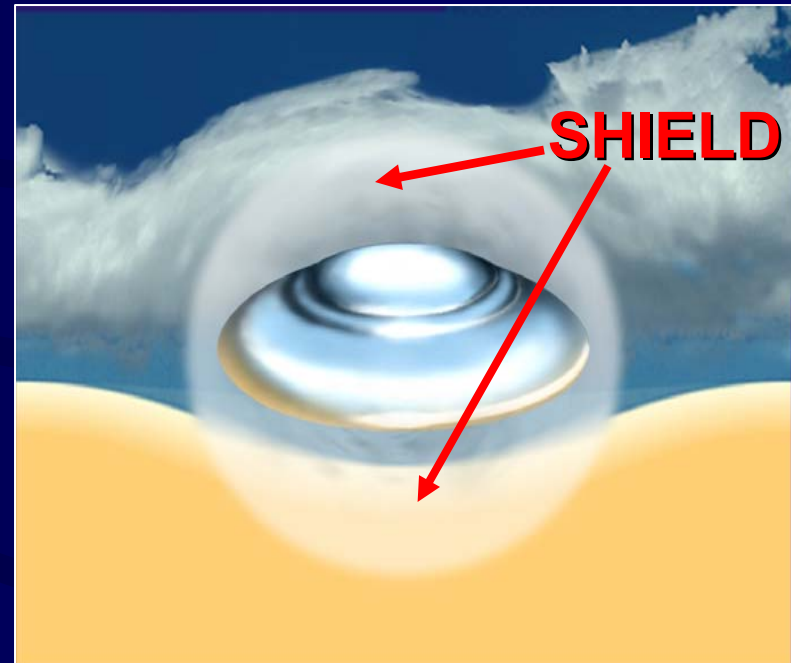

SHIELD INERTIA ($m \rightarrow 0$) AND
ACCELERATION "a" WILL
INCREASE ASTRONOMICALLY

"Inertia as a zero-point Lorentz field" Haisch, *Phys. Rev. A*, V.49, N.2, 1994

NASA Force Field for Astronauts

Megavolts protect them from charged space radiation

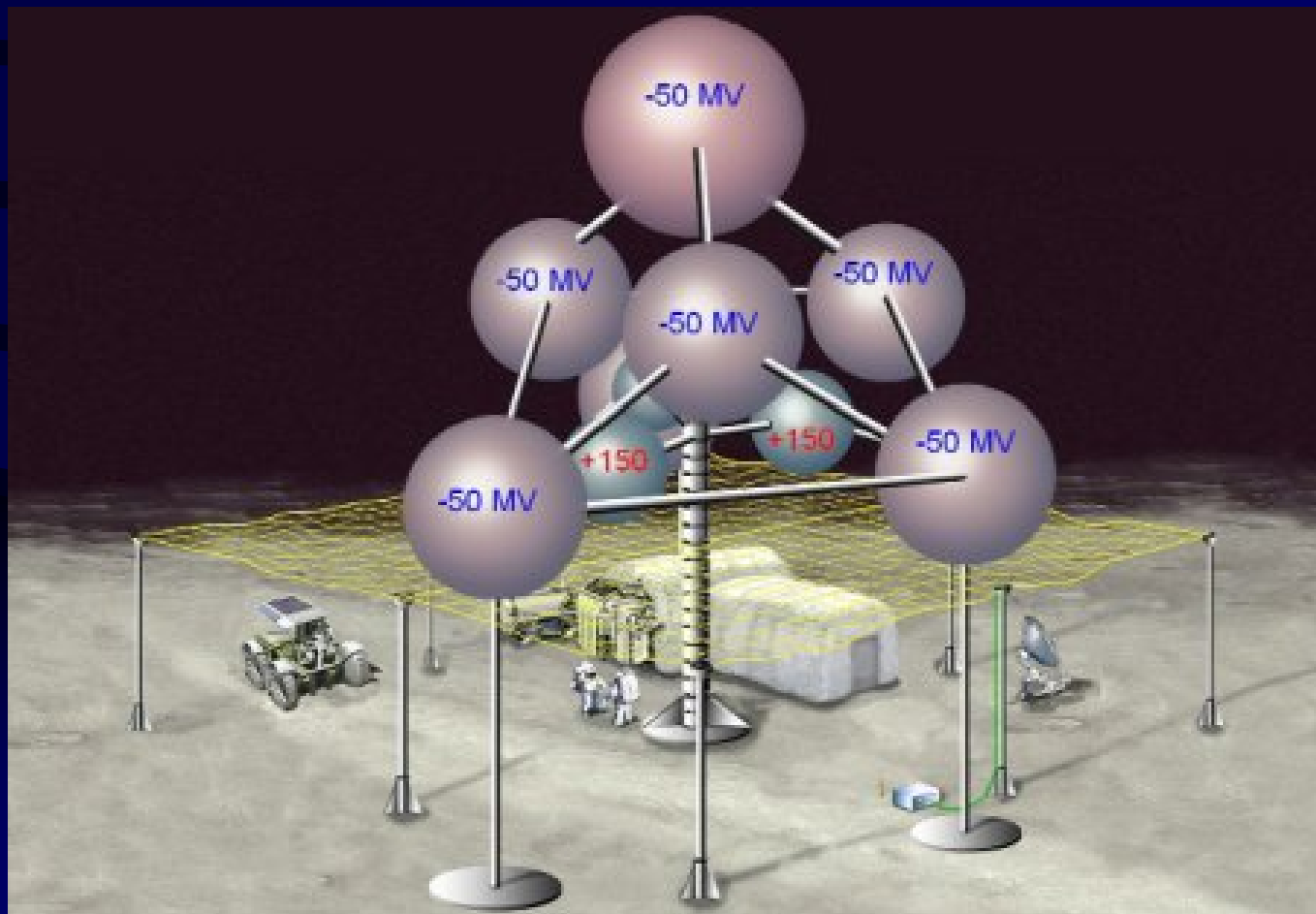



V. 12,
1997

ALTERNATIVE SCIENCE

Recently, two 1956 military documents, "Electrogravitics Systems" and "The Gravitics Situation," originally published by the Gravity Research Group of London (Special Weapons Study Unit), were declassified. Outlining T. Townsend Brown's antigravity discovery (see *Atlantis Rising*, Number 22, p. 35), and the subsequent Project Winterhaven, they were a vital new chapter in aviation research. For example, the documents state, "Unlike the turbine engine, electrogravitics is not just a new propulsion system, it is a new mode of thought in aviation and communications, and it is something that may become all-embracing."

To explain, "electrogravitics" is the science of using high-voltage electricity to provide propulsive force to aircraft or spacecraft of certain geometries. Or as Jeanne Manning explains, "The apparatus is pulled along by its self-generated gravity field, like a surfer riding a wave." Its discovery is often credited to Thomas Townsend Brown, a physicist who was encouraged by his professor, Dr. Paul Biefeld, a former classmate of Albert Einstein. However, there are those who say that Professor Francis Nipher's experiments, electrically charging lead balls, published in the *Electrical Experimenter*, in 1918, predates Biefeld/Brown. Unknown to many unconventional propulsion experts, T. Townsend Brown's electrogravitics work after the war involved a multinational project. American companies such as Douglas, Glenn Martin, General Electric, Bell, Convair, Lear, and Sperry-Rand participated in the research effort. Countries such as Britain, France, Sweden, Canada, and Germany also had concurrent projects from 1954 through 1956.

Furthermore, through the investigative effort of Dr. Paul LaViolette (read Len Kasten's article on LaViolette's research on pulsars elsewhere in this issue), it has become clear that electrogravitics became an integral part of the B-2 Stealth Bomber today, giving it an

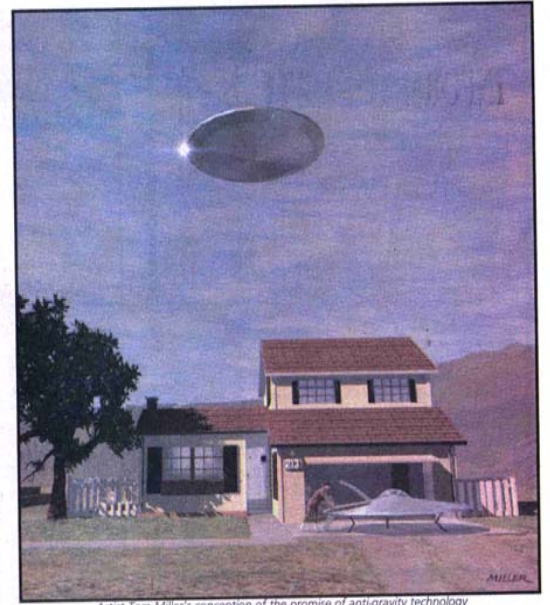

Artist Tom Miller's conception of the promise of anti-gravity technology

**Raising Questions:
Reopening the File
on Electrogravitics**

*From T. Townsend Brown to John Searle,
What Do the Documents Actually Show?*

Tom Valone, *Atlantis Rising*, Vol. 24:39, 2000

BY THOMAS VALONE

SEE OUR GREAT 8-PAGE CATALOG SECTION BEGINNING ON PAGE 74

the "differently charged elements" (with the voltage source). Ignition of these massive dielectrics provided the most propulsive force when

Continued on Page 41
Number 24 • ATLANTIS RISING 39

Propulsion theories of UFOs are topics of books, journals, videos, DVDs, TV shows, patents, and articles

The Antigravity Research of T. Townsend Brown

Many readers may recall the name of T. Townsend Brown (mentioned briefly in the previous article) as it was historically associated with UFOs. Brown was the first director of the now-defunct—but once very active—National Investigations Committee on Aerial Phenomena (NICAP), a Washington, D.C.-based lobby group that was very instrumental in the 1960s for getting congressional leaders interested in the UFO mystery. But what the majority may not realize was that Brown was also a very highly acclaimed physicist who held many patents and worked on a variety of highly classified projects.

It may well have been that Brown served as a very important "link" between the UFOlogical community and work being done in the 40s and 50s on what in scientific circles is best known as "Electrogravitics

Systems." There are even some who suggest that Brown's work in this field may have been assisted by his knowledge of the crash landing of a spaceship near Roswell, New Mexico. Because of his close dealings with the government and many private aerospace firms (both in the United States and abroad) he would have easily had access to knowledge considered to be on the "cutting edge."

According to Thomas Valone, a licensed professional engineer and head of the Integrity Research Institute (1377 K Street, N.W., Washington, D.C. 20005), some of Brown's early patterns showed designs that look very much like the familiar "flying saucer" seen throughout North America during this time period. In fact, in the group's recently published report titled *Electrogravitics Systems—Reports on a New*

Propulsion Methodology, Valone sees a very strong tie between Brown's discoveries and the development of the B-2 Stealth Bomber.

"There is," he says, "substantial evidence that the electrogravitics research of the 1950s actually resulted in the B-2 Stealth Bomber auxiliary propulsion system." In the report, an article by Dr. Paul LaViolette is summarized further reach these conclusions:

1. The B-2 charges the leading edges of its wing-like body, with high voltage;
2. The B-2 is shaped just like T.T. Brown suggested an electrogravitic craft should look, for maximum charge separation;
3. Northrup tested leading-edge charging in 1968;
4. T.T. Brown suggested that the craft should be powered by a flame-jet generator like the

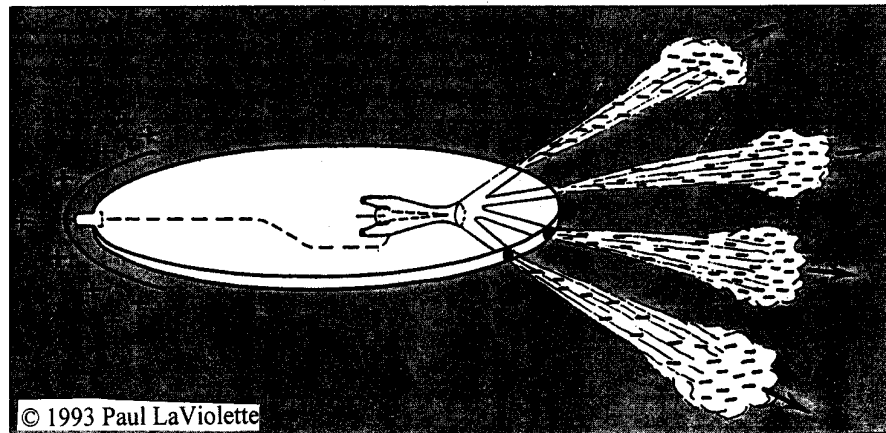

A version of the flying disc design that Brown proposed for development under Project Winterhaven.

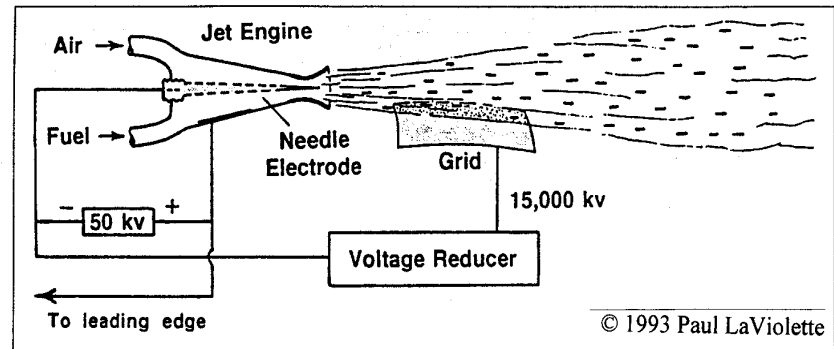

A high-voltage flame-jet generator.

5. *Aviation Week* admits the existence of "dramatic, classified technologies" applicable to "aircraft control and propulsion" on the B-2;
6. *Aviation Week* also disclosed that the ceramic RAM on the B-2 outer skin is powdered depleted uranium, which just happens to have a dielectric constant of three times that of the high-K dielectrics tested in the 1950s (barium titanate oxide);
7. The B-2's Emergency Power Units (EPU) can work at high altitudes or even in space, driving an electrical generator;
8. Edward Aldridge, the Secretary of the Air Force, admits that the B-2 creates *no vapor trail* at high altitudes.
9. The decomposed gases from

the EPU's can function as the ion-carrying medium, according to T.T. Brown.

From this point it is not hard to reach out even further and safely conclude that a great deal of what is going on inside Area 51 (Nevada's top secret military base) is based upon the work of Brown and others who long ago saw another way to reach the stars besides utilizing rockets that need very heavy fuel payloads.

After reading the available literature, even seasoned scientists have had to agree that Brown's propulsion methods may be our best bet in reaching out to the planets in our solar system that we might possibly be able to visit even now if these discoveries were not being kept under lock and key by those few who would deem it necessary to utilize this valuable knowledge for their

own private gain.

John Searl's Work

British engineer John Searl claims to have built over 50 versions of his own "flying saucer," and has been receiving media attention—no matter how limited—for a number of years with his claims of having developed a noiseless, propulsion-free, levity disc that requires no fuel and flies vertically when taking off and landing. Searl even makes the bold claim that one of his craft actually flew around the world several times in the early 1970s...apparently without detection. It's claimed that "ultra-high voltage electro-static force fields are developed by segmented rings rotating in the disc's periphery. The craft's direction is controlled by varying voltage around the edge, thus producing unbelievable speed and agility."



The Searl Levity Disk...a man-made Flying Saucer goes aloft.

**Brown & Bahnson Lab
studied
electrogravitics
designs and received
over a dozen patents**

**US Patent
#2,958,790**

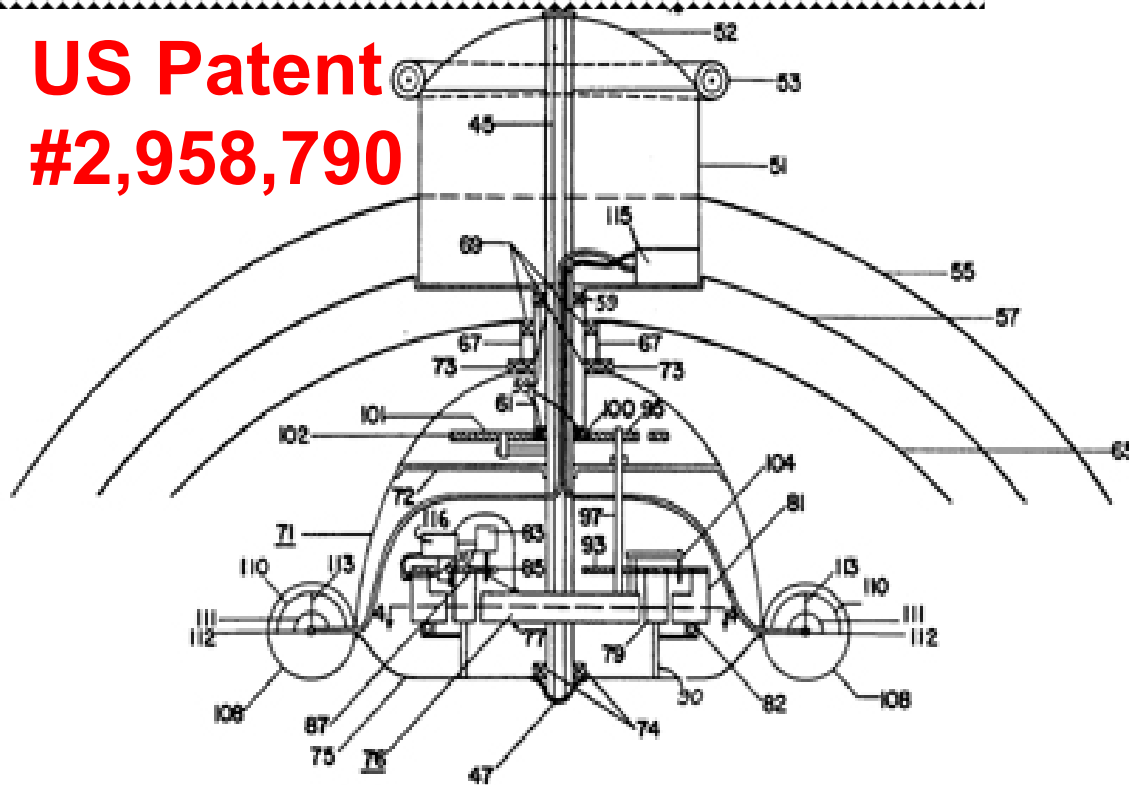

FIG. 3



Experimental tri-axial electrogravitic electrode
3 feet in diameter

Lifter Demonstration – Triangular UFO

Built and tested by Tim Ventura,
AmericanAntigravity.com



Disclaimer: Lifters do not show electrogravitics principles, only ion wind forces

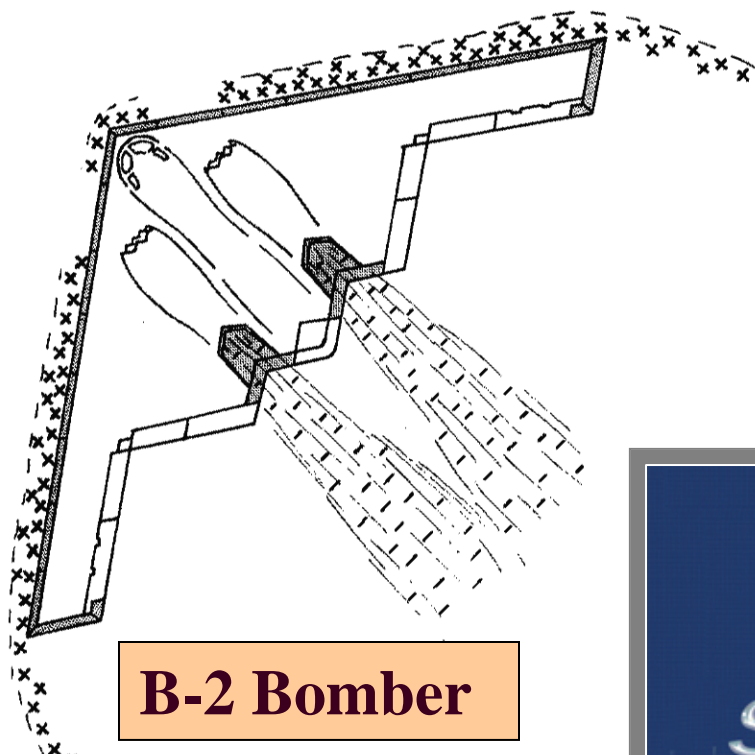

B-2 Bomber

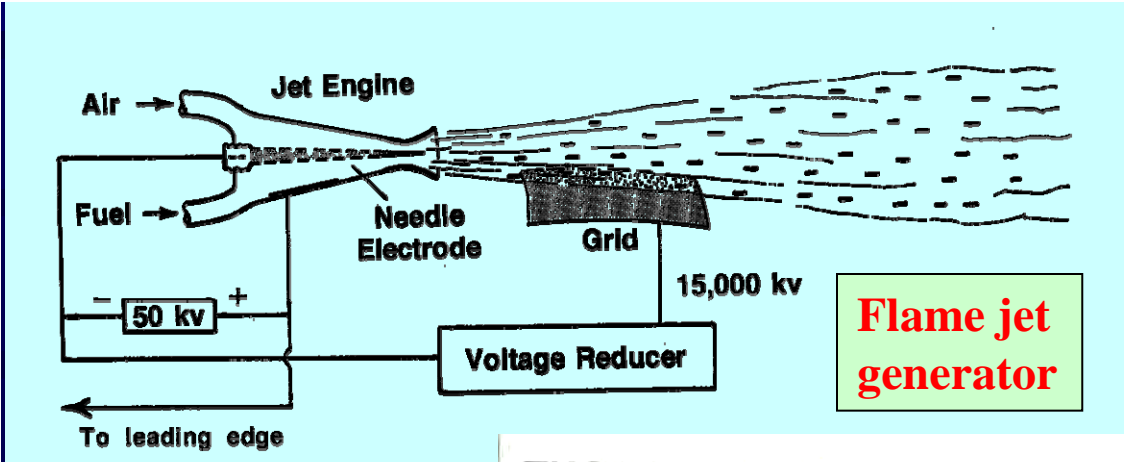

Flame jet generator

ELECTRO GRAVITICS SYSTEMS
 Volume I
 Thomas Valone, PhD

**THOMAS TOWNSEND BROWN:
 BAHNSON LAB 1958-1960**

ELECTROGRAVITICS LEVITATION EXPERIMENTS
 ORIGINAL SILENT FOOTAGE TRANSFERRED TO VHS VIDEO



See New Styles of Electrogravitic Prototypes Designed for Vertical Flight and Hovering, Captured on Film at the Bahnson Laboratory

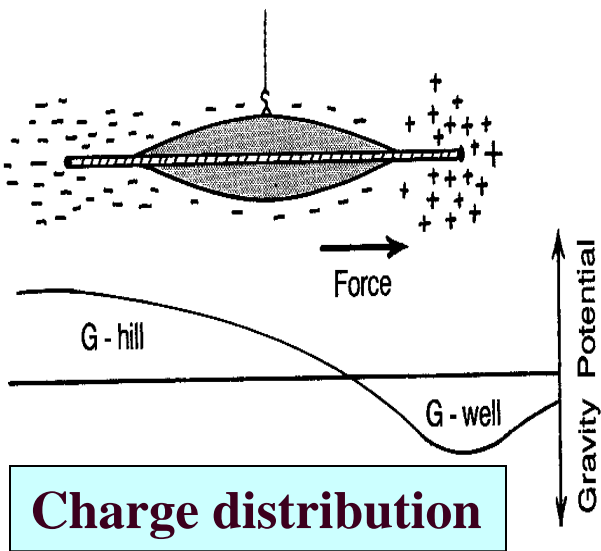

Charge distribution

Disc Speed & Voltage Exponential

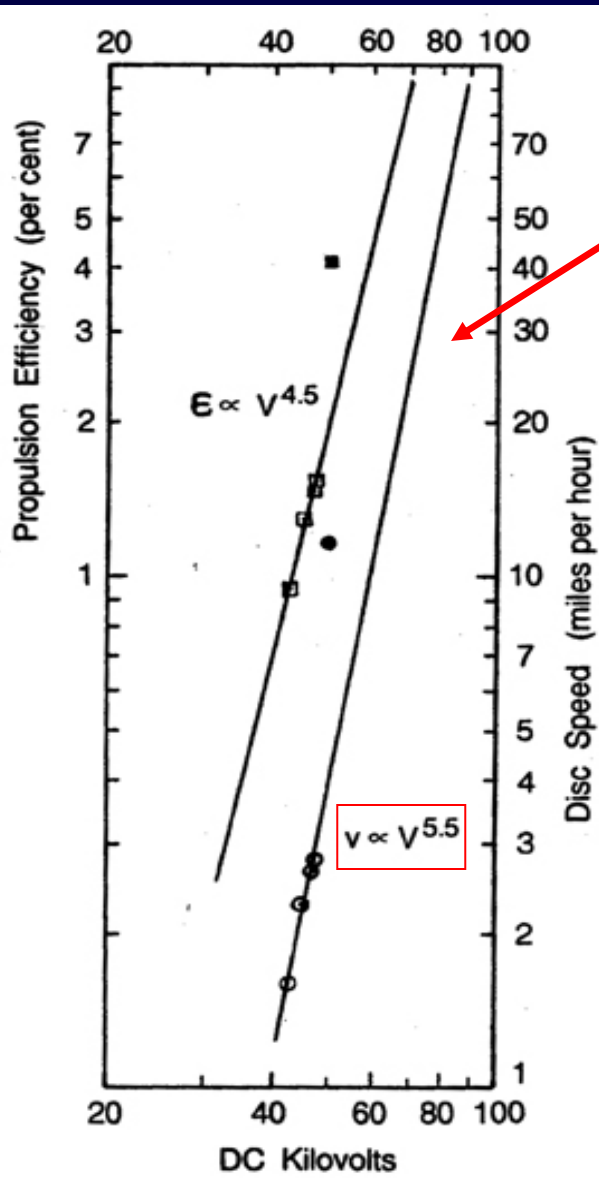

Office of Naval Research tests show disc speed has 5th power dependence on voltage

Army Research Lab tests show the Biefeld - Brown effect is related to ionic mobility and produces a force of

1.2 lb/kW
or 5 N/kW

1952 T. T. Brown tests

ELECTRO GRAVITICS II

Validating Reports on a New Propulsion Methodology

Thomas Valone, PhD

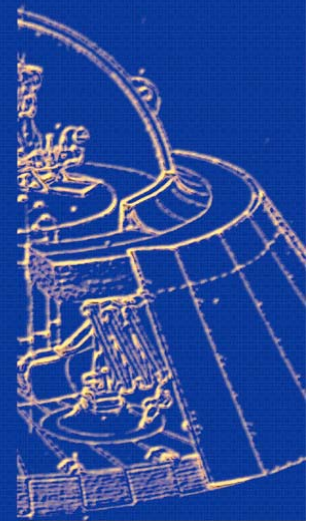
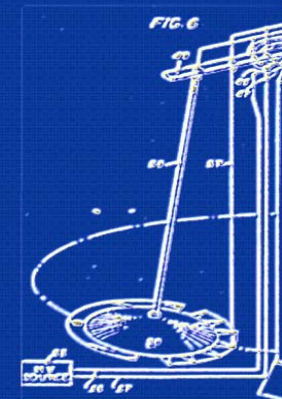

(12) **United States Patent**
Campbell

(10) **Patent No.:** US 6,317,310 B1
(45) **Date of Patent:** Nov. 13, 2001

- (54) **APPARATUS AND METHOD FOR GENERATING THRUST USING A TWO DIMENSIONAL, ASYMMETRICAL CAPACITOR MODULE**
- (75) **Inventor:** Jonathan W. Campbell, Harvest, AL (US)
- (73) **Assignee:** The United States of America as represented by the Administrator of the National Aeronautics and Space Administration, Washington, DC (US)
- (*) **Notice:** Subject to any disclaimer, the term of this patent is extended or adjusted under 35 U.S.C. 154(b) by 0 days.
- (21) **Appl. No.:** 09/520,817
- (22) **Filed:** Mar. 8, 2000
- (51) **Int. Cl.:** H01G 4/228; H05K 7/02
- (52) **U.S. Cl.:** 361/306.1; 361/811
- (58) **Field of Search:** 361/306.1, 15, 361/16, 17, 715, 821, 311

- (56) **References Cited**
U.S. PATENT DOCUMENTS
- 4,392,179 * 7/1983 Nelson et al. 361/234
- * cited by examiner
- Primary Examiner*—Anthony Dinkins
(74) *Attorney, Agent, or Firm*—James J. McGroary
- (57) **ABSTRACT**

A capacitor module system is provided for creating a thrust force. The system includes a capacitor module provided with a first conductive element having a cylindrical geometry. The first conductive element can be a hollow cylinder or a solid cylinder. The capacitor module also includes a second conductive element axially spaced from the first conductive element and of smaller axial extent. The second conductive element can be a flat disk, a dome, or a conductive tip at the end of a dielectric rod. A dielectric element is disposed between the first conductive element and the second conductive element. The system also includes a high voltage source having first and second terminals connected respectively to the first and second conductive elements. The high voltage source applies a high voltage to the conductive elements of sufficient value to create a thrust force on the module inducing movement thereof.

10 Claims, 3 Drawing Sheets

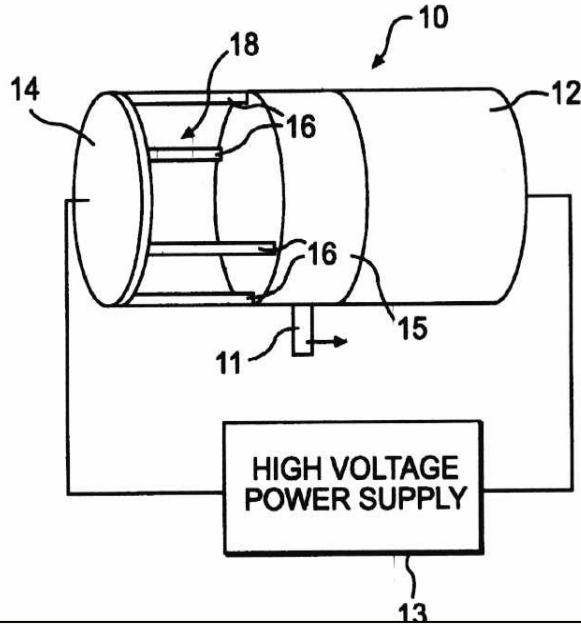

NASA Patents on Electrogravitics: 2001 – 2004

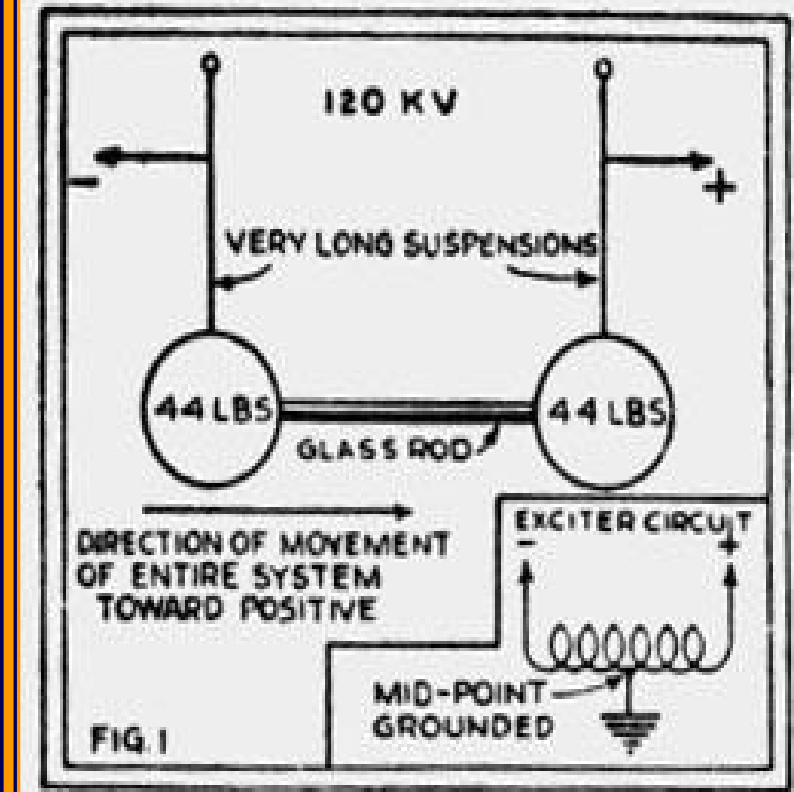

A SIMPLE TYPE OF GRAVITATOR IS SHOWN IN THE ABOVE ILLUSTRATION.

“How I Control Gravitation”
Science & Invention - T.T. Brown
– Aug. 1929

Electrokinetic equation explains them both .

THE ZINSSER EFFECT

COMPLETE STORY OF THE UNUSUAL
ELECTROGRAVITY INVENTION
OF RUDOLF G. ZINSSER

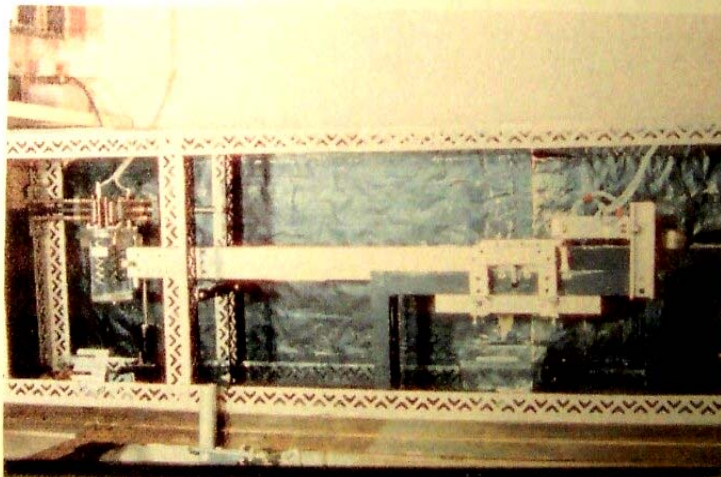

Edited by
Thomas Valone, PhD, PE

Integrity Research Institute

**Small signal
energy input
creates long-
lasting force
production**

**Analyzed in
*Electrogravitics II***

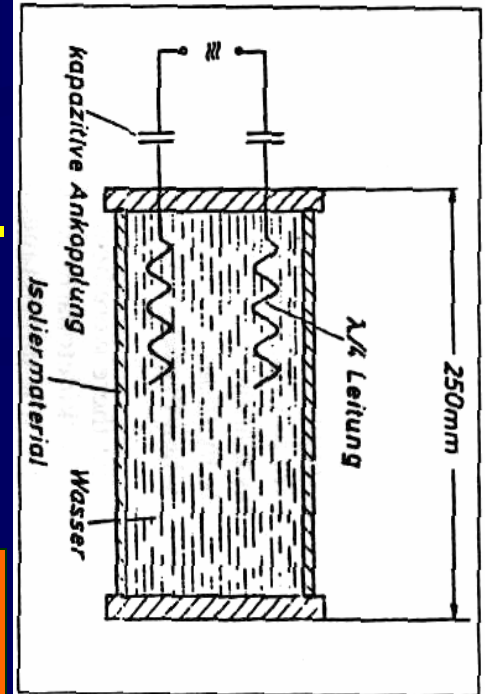

- I met inventor in 1980, 1981
- Electrical input to capacitor
- Storage effect that retains force
- Probably the most efficient
- Created health improvement
- Patented invention 4,085,384

**Zinsser can now be explained
by the electrokinetic equation**

Zinsser's Force Balance

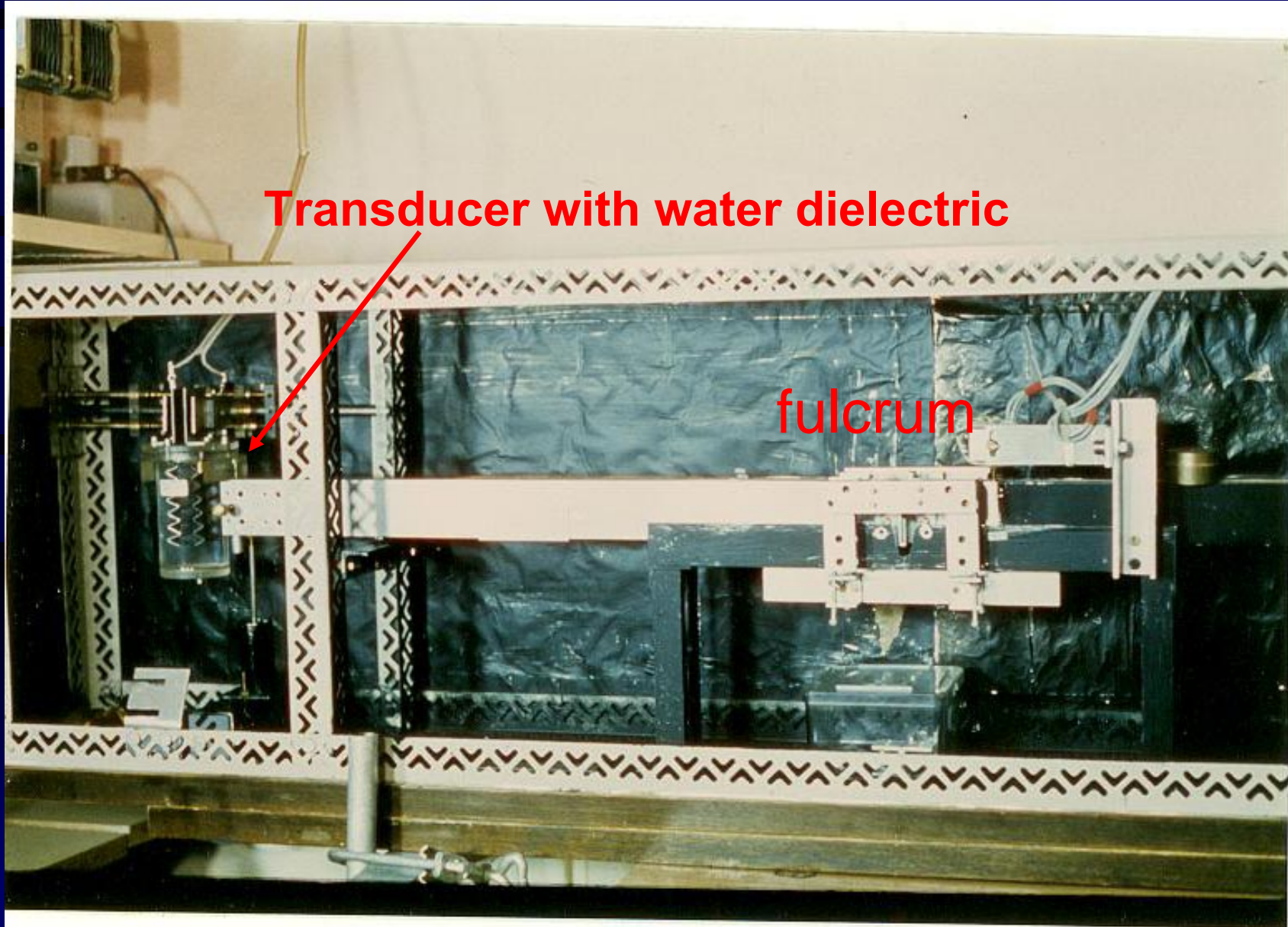

Jefimenko's Electrokinetic Equation

Professor Emeritus, W. Virginia University

$$\mathbf{E}_k = -\mu_0 \frac{\partial I}{\partial t} \frac{x}{w} \mathbf{j}$$

- Time derivative of current
- Fast pulsed current with short rise time will produce the **largest force**

chance of snow flurry; clearing in afternoon; fair, cool to night.
 Tomorrow: Increasing cloudiness, milder, chance of rain at night.
 Temperatures Yesterday: Max. 37.3; Min. 29.7
 Today's Probable Range: Max., 41; Min. 29
 Humidity at 3 p. m. Yesterday: 10%
 Expected Humidity This Afternoon: 68-70%
 Reports, Maps, Sec. 3, Page 4

Herald Tribune

115th Year VOL. CVY NO. 25,517

230 West 41st Street, New York 36, N. Y. Telephone PEEnsylvania 6-1000

Nov. 22, 1955



FLYING SAUCER OF THE FUTURE? A reproduction of an oil painting by M. Gluhareff, president of Gluhareff Helicopter & Airplane Co., Beach, Calif., showing a "saucer-shaped" aircraft or space ship flying beyond the earth's atmosphere and gravity field. Mr. Gluhareff claims to have flown "at moderate speed" over the New York-New England area in a propulsive blast of the electron beams from the visible, giving the saucer a translational force.

Space-Ship Marvel Seen If Gravity Is Outwitted

Speeds of Thousands of Miles An Hour Without a Jolt Held Likely

This is the second of a series of articles on new pure and applied research into the mysteries of gravitation in America through developing a lightweight auto-

Able to Go 'Where We Want'

New 'Air Dream—Planes Flying Outside Gravity

This is the third of a series of three articles on new pure and applied research into the mysteries of gravity and the efforts to devise ways to overcome it.

By Ansel E. Talbert
 Military and Aviation Editor

The current interest in America's aircraft and electronics industries in finding out whether gravity can be controlled or "cancelled out" is not confined to imaginative young graduates of engineering and scientific schools.

Some of the two industries'

most experienced and highly regarded leaders today are engaged directly or deeply interested in theoretical research relating to gravity and universal gravitation. Their basic aim is eventually to build "hardware" in the shape of planes, earth satellites and space ships "which can go where we want and do what we want without interference from gravity's mysterious trans-spatial pull."

Bell Is Optimistic

Lawrence D. Bell, whose company in Buffalo built the first piloted aircraft in history to fly faster than sound, is certain that

INDEX

Re Split Over Labor Issue Dispute May To Eisenhower

Reprinted in **Electrogravitics II**

115th Year VOL. CVY NO. 25,517

230 West 41st Street, New York 36, N. Y. Telephone PEEnsylvania 6-1000

Conquest of Gravity Aim Of Top Scientists in U. S.

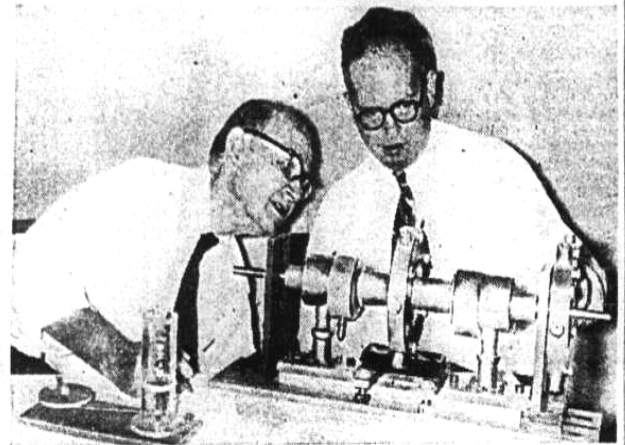

ANTI-GRAVITY RESEARCH—Dr. Charles T. Dozier, left, senior research engineer and guided-missiles expert of the Convair division of General Dynamics Corp., conducting a research experiment toward control of gravity with Martin Kaplan, Convair senior electronics engineer.

Changes Far Beyond Atom Are the Prize

Revolution in Power. Air, Transit Is Seen

This is the first of a series of new pure and applied research into the mysteries of gravity and efforts to devise ways to counteract it.

By Ansel E. Talbert
 Military and Aviation Editor

The initial steps of an almost incredible program to solve the secret of gravity and universal gravitation are being taken today in America's top laboratories and re-



IN CHARGE—George S. Trimble Jr., vice-president in charge of advanced design planning of Martin Aircraft Corp., is organizing a new Research Institute for Advanced Study to push a program of theoretical research on gravitational effects.

Helicopters to Drive Cabinet

Electrogravitic Craft Demonstration – Norton Air Force Base 1988

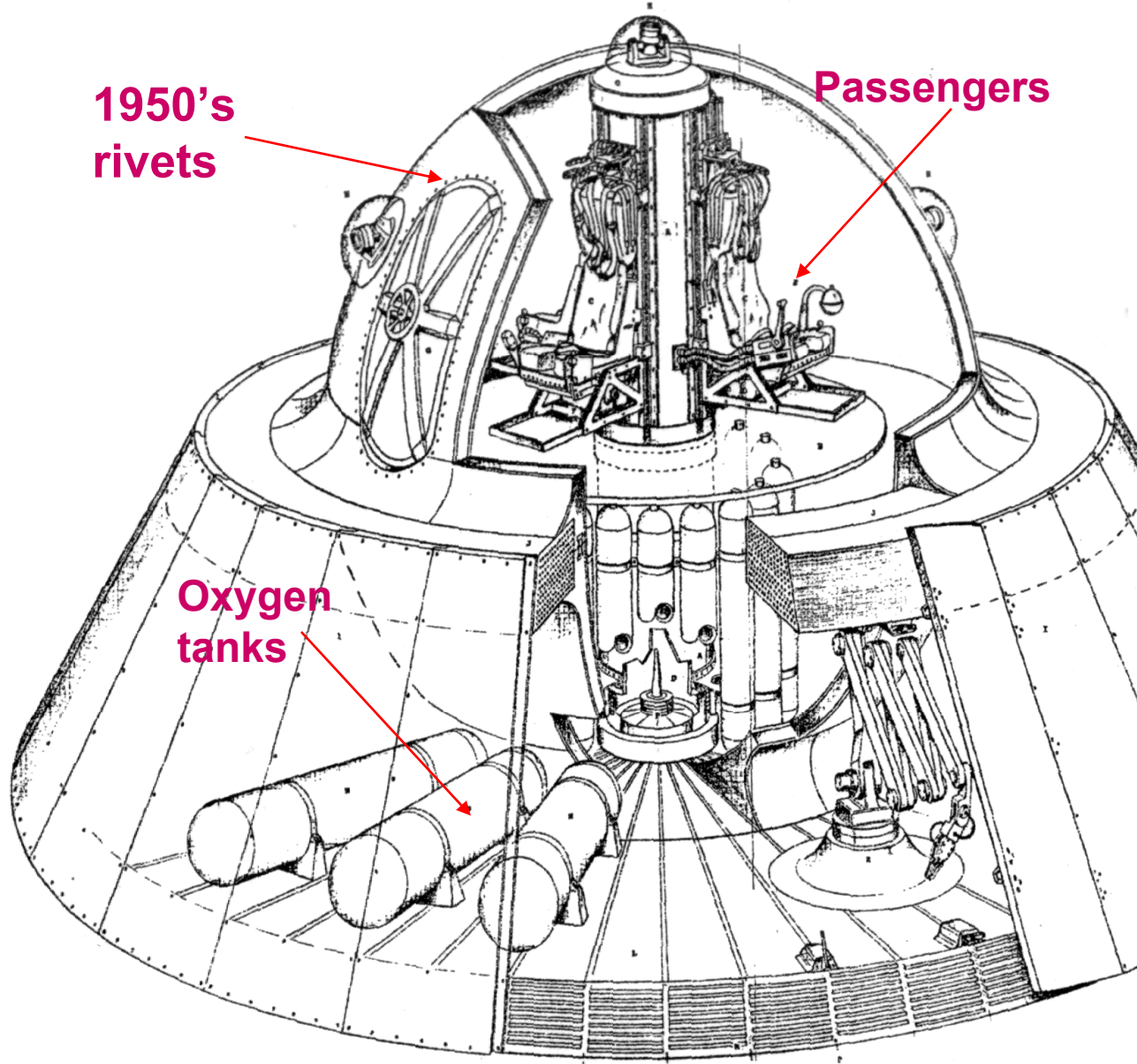

Complete story
by Mark
McCandlish in
Disclosure by Dr.
Steven Greer and
Electrogravitics II
by Tom Valone

Investigated by
Dr. Hal Puthoff,
former CIA
contractor

Dr. Hal Puthoff's Due Diligence

Regarding a Norton AFB 1988 Demonstration

Hal Puthoff, in a private email communication to me (Feb. 10, 2006) explains,

“All I was able to determine by my due diligence was:

- (1) to **independently interview the source of the story** and verify that, indeed he did tell the story to the individual who had passed it on to me, and
- (2) to **independently interview yet another individual** who had heard a similar story from a separate source.

BUT, I was never able to verify that the story itself was true, only that there were two individuals who said it was true. I then corrected you with my statement (exact quote):

‘... the story remains in my 'gray basket' only as 'possibly' true.’”

Impulse Gravity Generator

Podkletnov Capacitor array exhibits new effect above 500 kV

“Glowing discharge unlike a spark emanates from superconducting cathode (-) toward the copper anode (+) and propagates beyond it, in a collimated beam....millijoule range of energy”

→ Electrokinetic force opposite to pulsed current direction

www.arxiv.org/abs/physics/0209051 and
www.arxiv.org/abs/physics/0108005

Podkletnov, Evgeny

Airport of the Future



www.searleffect.com

Antigravity by J. Thomas Jr.

Figure 12. This is a rendition, a picture that my son has done. A composite picture showing what we envision for the future. We envision these IGVs right along side conventional aircraft and they will take you just about anywhere you want to go, on or off the earth.

To the Stars

Zero point energy emerges from realm of science fiction, may be key to deep-space travel

WILLIAM B. SCOTT/AUSTIN, TEX.

At least two large aerospace companies and one U.S. Dept. agency are betting “zero point energy” could be the next breakthrough in aerospace vehicle propulsion, and are backing those bets with seed money for research.

If their efforts pay off, ZPE powerplants might enable Mach 25 hypersonic aircraft, quiet 1,200-seat hypersonic transporters that fly at 100-mi. altitudes and cover 12,000 mi. in about 70 min., and even trips to the Moon.

ONE OF THOSE companies, Boeing, has teamed with the U.S. Dept. of Defense to launch “Project Greenglow” in 1986 “to provide a focus for research on novel propulsion systems and the technologies to power them,” said R.A. Evans, the project leader, in a technical paper last year. Although funding levels have been modest, Greenglow is exploring ZPE as one element



NASA BPP/LES BOSSINAS

PE-relativistic energy is difficult to harness, and is difficult to harness by meticulous

Spacecraft capable of interstellar travel will approach the speed of light, and may have to extract energy from the vacuum of space. However, researchers could be years or decades from achieving the breakthroughs necessary to build such a propulsion system.

cowatts of power. That still leaves some critical questions. Still, the government